



TW - Serie

TIG

Toches and spare parts

Catalogue

CERTIFICATE

Management system as per

DIN EN ISO 9001:2008

Evidence of conformity with the above standard(s) has been furnished
and is certified in accordance with TÜV PROFICERT procedures for



Holch Schweißbrenner GmbH
Bühlstraße 14
D-57080 Siegen

scope:

Development and production of
inert gas-welding torches and spare parts



Certificate registration No. **73 100 1110-29**

Certificate valid from 2015-04-16 to **2018-04-15**

Audit report No. 4290 7062



O. Malt
Darmstadt, 2015-04-16
Certification body of TÜV Hessen
– Head of Certification body –

WIG-Schweißbrenner mit TW - Brennerkörpern



HSN 807

WIG Brennerkörper



HSN 829-1

Forma - Griffschale mit Kugelgelenk



Art.Nr.: 91914601



(DD)

Art.Nr.: 91914621



up/down

Art.Nr.: 91914641



(ED)

Art.Nr.: 91914611



(ED) Poti

Art.Nr.: 91914631



Art.Nr.:
91914603

MG - Griffschale mit und ohne Kugelgelenk



Art.Nr.: 91914031



Art.Nr.:
91915001



Art.Nr.: 91914033



Art.Nr.:
91915001



Art.Nr.: 91914061



Art.Nr.:
91914603

HSN 832

Maschinenseitige Anschlüsse WIG SK25 und SK35



Schweißkabelstecker SK 25



Art.Nr.: 91918201



Schweißkabelstecker SK 25 sep. Gasführung



Art.Nr.: 91918321



Schweißkabelstecker SK 35



Art.Nr.: 91918301



Schweißkabelstecker SK 35 sep. Gasführung



Art.Nr.: 91918311



SK 35 gasgekühlt



Art.Nr.: 91918322



SK 35 wassergekühlt



Art.Nr.: 91918312

HSN 812

Steuerleitungsstecker

1-pol. Bananen-Stecker
91904158 passend Oerlikon, SAF



1-pol. Amphenol
für Plasma-Schweißbrenner
91904191



2-pol. Cloos-Stecker
91903701



2-pol. Redel-Mini-Stecker
91904152 passend ESAB



2-pol. Cannon-Stecker
91904151 passend ESAB



2-pol. Buchse R2D2 metall.
91904197 passend China Maschine



3-pol. Stecker R3D3 metall.
91904196 passend China Maschine



3-pol. Alcatel-Stecker
91904173 passend Cloos-Herborn
Esseti, Firmer, Variamp, Woltersdorf



3-pol. Gys / Preh-Stecker
91904174 passend Ess, Jäckle



3-pol. Klinkenstecker 3,5mm
91904186 passend Lorch, Oerlikon



3-pol. Klinkenstecker 6,3mm
91904182 passend Lorch, Oerlikon



3-pol. Tuchel-Stecker
91904101 passend versch. Hersteller



3-pol. Amphenol-Stecker
91904183 passend TOP



3-pol. Amphenol-Stecker
für Plasma-Schweißbrenner
91904181



4-pol. Selco-Stecker
91904134



4-pol. Amphenol-Stecker
91904131 passend Kempfi,
UTP, Zeuna



5-pol. Cebora-Stecker
91904172



**5-pol. Tuchel-Stecker mit
Bajonettverschluss**
91904111 passend versch. Hersteller



**5-pol. Amphenol-Tuchel-Stecker
mit Rundkontakten, schraubbar**
91904195 p. Cloos-Haiger / Weco



5-pol. Tuchel-Stecker, schraub.
91904112 passend Hermann



6-pol. Harting-Stecker
91904121 passend Migatronik



HSN 815A

Steuerleitungsstecker

6-pol. Schaltbau-Stecker
91904163 passend Elektra-Beckum, Metabo



6-pol. Amphenol-Stecker
91904169 passend CEA



7-pol Amphenol-Stecker
91904178 passend Kemppi



7-pol. Rehm-Stecker
91904161 passend Erfi, Hydro Tech, Migatron



7-pol. Cemont-Stecker
91904176



7-pol. Amphenol-Tuchel-Stecker mit Rundkontakten, schraubbar
91904194 passend Selco/Weco/Stel



7-pol. Tuchel-Stecker
91904113 passend Castolin, Dalex, Fronius, Kjellberg



7-pol. wie Cebora-Stecker
91904165 passend Cloos mit Poti



8-pol. Burdy-Stecker
91904189 passend EWM



8-pol. Rebel-Stecker
91904180 passend ESAB



9-pol. Computer-Stecker
91904177 passend Lorch



9 - pol. Fronius-Flachstecker
91904164



10-pol. Cebora-Stecker
91904175



10-pol. Amphenol-Stecker
91904188



12-pol. Stecker
91904166 passend Rehm



12-pol. Weipu-Stecker
91904153 passend Flame



12-pol. Burdy-Stecker
91904167 passend EWM Tetrix



14-pol. Stecker
91904135 passend Miller



14-pol. AMP-Stecker
91904136 passend Telwin, Alphaforce



HSN 815B

Component-drawings with spare parts

Welding torches TIG gas-cooled	page
Torch 9-TW	11 - 18
Torch AS 17-TW	19 - 26
Torch SR 17-TW	27 - 34
Torch SR 26-TW	35 - 42
Torch ABL 220-TW	43 - 50
Welding torches TIG water-cooled	
Torch 12-1-TW	51 - 58
Torch AS 18-TW	59 - 66
Torch SR 18-TW	67 - 76
Torch wp-18SC-TW	77 - 84
Torch 20-TW	85 - 94
AUT-welding torches gas-cooled	
Torch AUT 210-S	95 - 100
Torch AUT 230-S	101 - 108
AUT-welding torches water-cooled	
Torch AUT 410-S	109 - 118
Tungsten-electrodes	appendix A
Sundries, parts and tools	appendix B
Custom made products	appendix C
Control line plugs and jacks	appendix D

**Deliveries are made in compliance with our terms
and conditions on next page only.
Subject to alteration!**

General terms and conditions of sale

1. These general terms and conditions apply to all our present and future business relations. Purchasers' standard terms and conditions at variance with them apply only if we have expressly assented to them in writing.
2. Our tenders are without engagement. The contract is formed only by our written acceptance of the Purchaser's order.
3. Our prices are in Euro without tax, customs duty, shipment, packing, insurance, etc. Prices only apply for the particular order.
4. Delivery is made ex-works (place of fulfilment) by the mode of shipment most favourable for us. Additional costs for a mode of shipment stipulated by the Purchaser are borne by the Purchaser. Goods are always shipped at the risk (loss, deterioration, delay) of the Purchaser.
5. Our scheduled delivery dates are without engagement. Compensation claims for delayed deliveries cannot be accepted. For production oriented reasons we reserve the right to deliver up to 10% more or less of the contracted quantity.
6. We must be notified in writing about any deficiency in writing immediately, at latest ten days after acceptance of the delivery. If the goods are defective, we can choose whether to make the good the discharge of our obligations by rectifying the defect (remediation) or by supplying defect-free goods (replacement) or by refunding the purchasing price and taking back the defective good. Equipment repaired by us has to be checked for correct function immediately upon reception. We repair defective goods at no charge in our shop. Additional used consumables are charged to the Purchaser. Further claims are excluded. We explicitly are not liable for property loss or economic loss of the Purchaser or their customers.
7. The purchase price is due 10 days after invoicing (discount of 2 percent deductible) or 30 days of invoicing net. Cash discount will only be granted if there are no arrears from previous invoices.
8. Until all our present and future outstanding accounts have been paid in full we reserve ownership of the goods. The Purchaser may process and / or sell the goods in the course of orderly business. The Purchaser assigns to us now by way of security all trade debts arising from reselling the goods in total or to the extent of our ownership share. After all our present and future outstanding accounts have been paid in full the Purchaser gains ownership of the goods. Place of fulfilment and exclusive court of jurisdiction for any legal disputes is Siegen, Germany. The laws of the Federal Republic of Germany apply to the exclusion of all international and supranational regulations governing (contract) law.
9. In case of any dispute regarding the above terms and conditions or its translation, the German language version in its original edition has higher priority than any other translated versions. We will sent the Purchaser a copy of our German language version at any time upon request.

Torch 9-TW gas-cooled



Holch Schweißbrenner GmbH
Bühlstraße 14
D-57080 Siegen

Phone: +49(0)271 387860-11
Telefax: +49(0)271 387860-29
E-Mail: info@holch-siegen.de
Web: www.holch-siegen.de



9-TW gas-cooled

110 Ampere at 100% duty cycle (DC) - 95 Ampere at 100% duty cycle (AC)

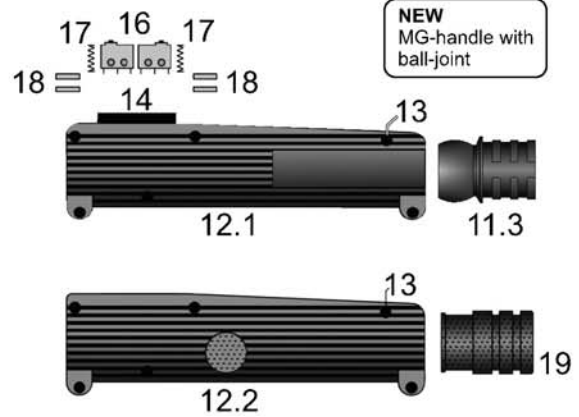
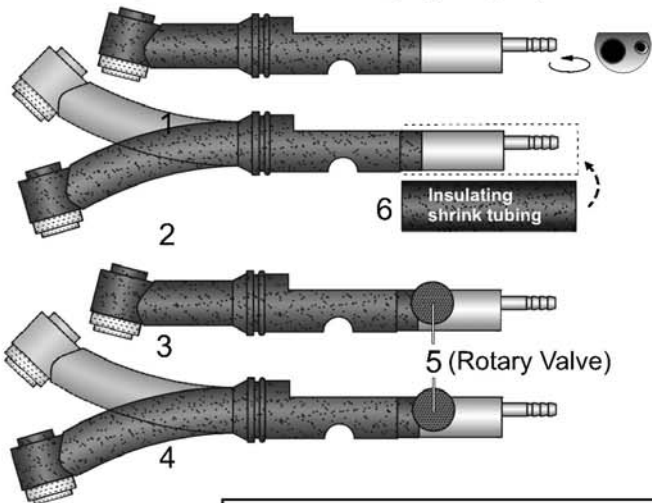

Forma WIG-handle with ball joint and different modular switch units

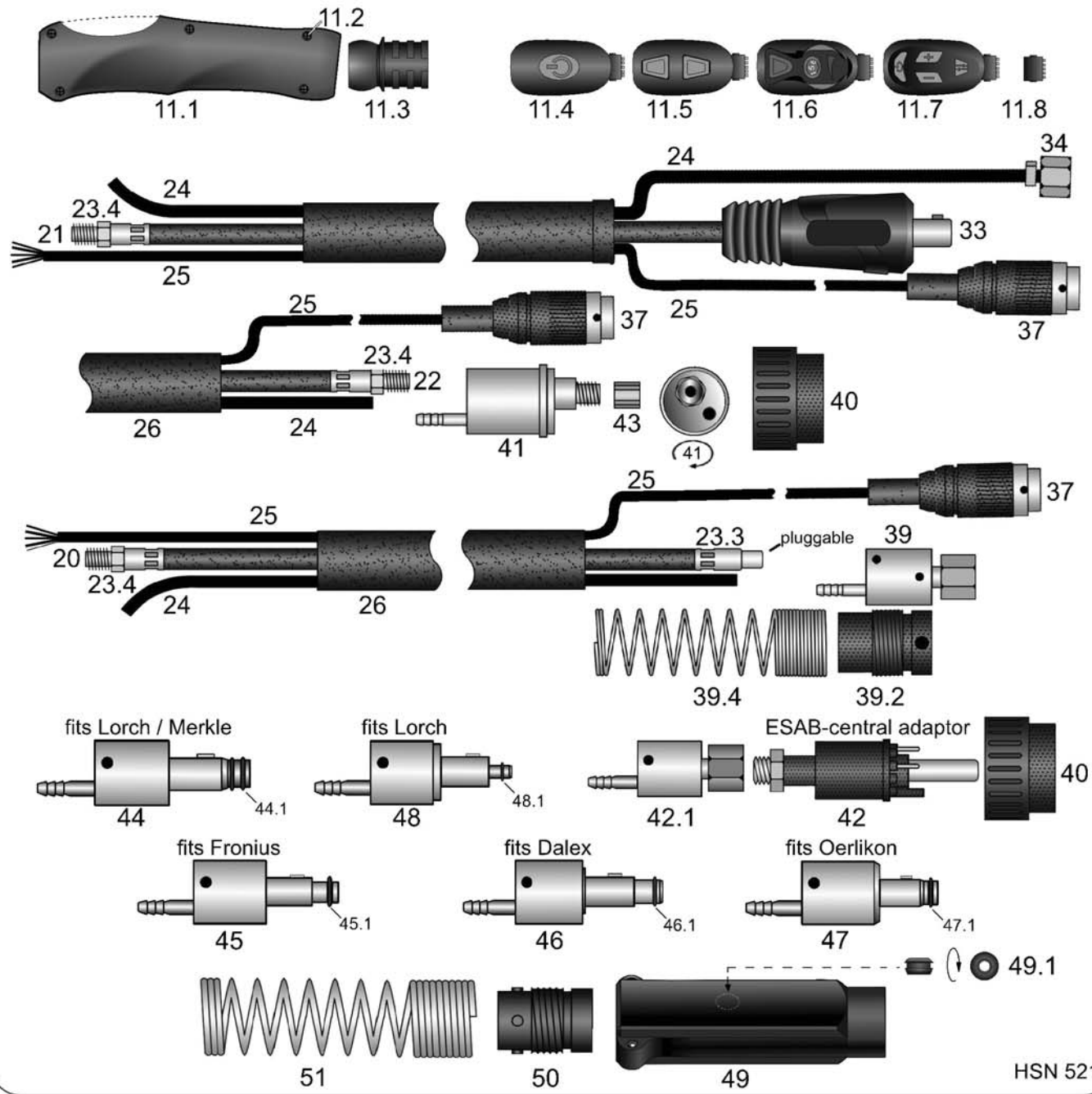

9 - TW gas-cooled spare parts

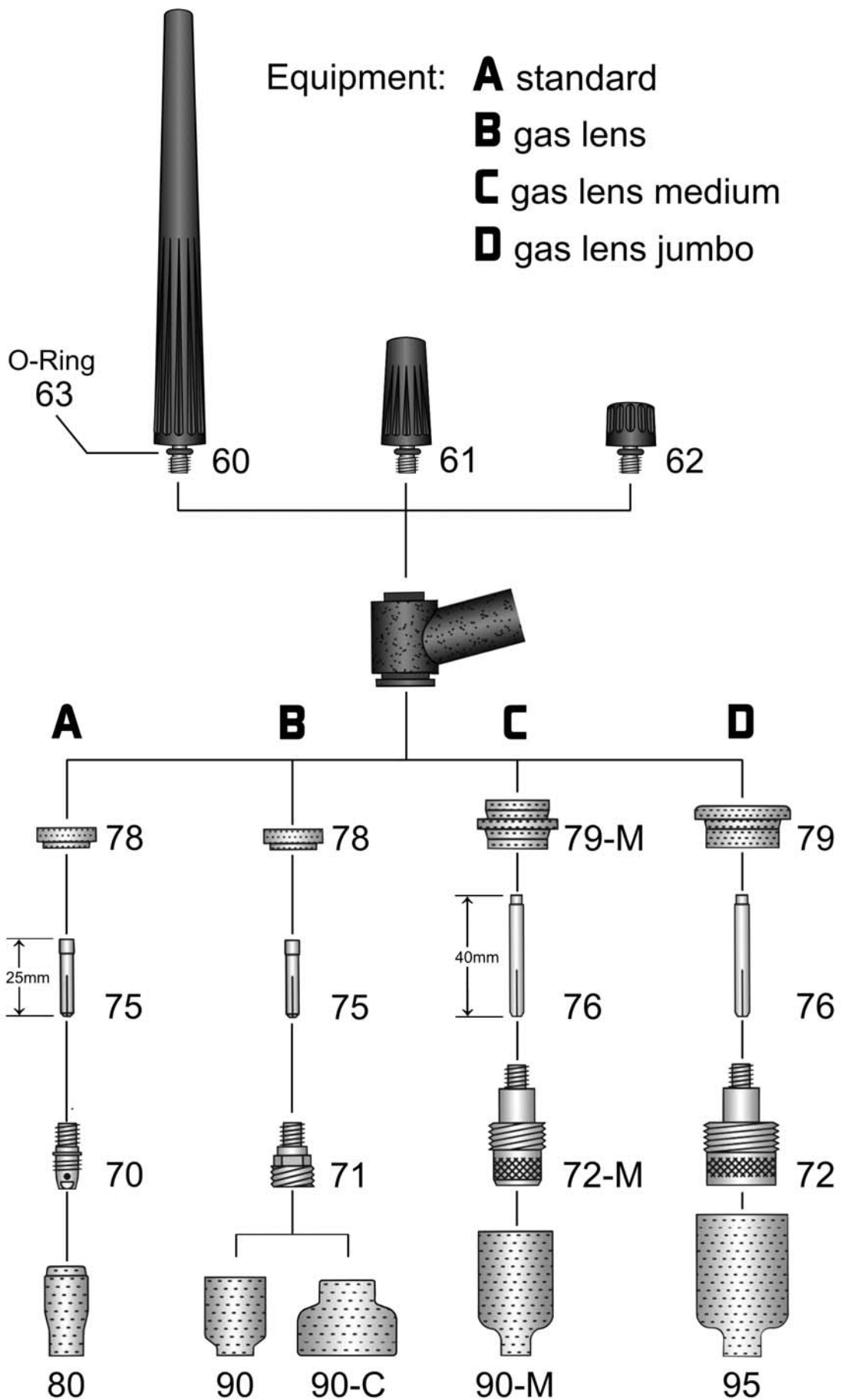

HSN 102-1

Welding-torch TIG gas-cooled**110A at 100% duty cycle (DC) - 95A at 100% duty cycle (AC)****Art.-No.**

Torches with first meter leather hose. Prices without leather on request. Machine side separate connections.

Torches and cable assemblies can be produced in excess lengths. Please find the different options and surcharges in the attachment "Custom made products" appendix C. We produce torches for more than 40 different brands of machines with different connection systems.

90500401	Torch 9-TW / 4m 25mm ²
90500801	Torch 9-TW / 8m 25mm ²

90600401	FLEX-torch 9F-TW / 4m 25mm ² neck flexible
90600801	FLEX-torch 9F-TW / 8m 25mm ² neck flexible

90700401	Valve torch 9V-TW / 4m 25mm ²
90700801	Valve torch 9V-TW / 8m 25mm ²

90800401	FLEX-Valve torch 9FV-TW / 4m 25mm ² neck flexible
90800801	FLEX-Valve torch 9FV-TW / 8m 25mm ² neck flexible

TIG-spare cable assemblies in different qualities, machine side with separate connections and Tichel plug, or, if ordered so, with the following connection systems:

wig92401	TIG-spare cable assembly gas-cooled 4m - please state desired design!
wig92801	TIG-spare cable assembly gas-cooled 8m - please state desired design!

The following surcharges for machine side connections are only to find prices quickly. Please use our catalogue "TIG machine side connections" to find a "T"number which identifies a machine side connection system completely.

29000101	Surcharge: machine side with EURO central adapter
29002005	Surcharge: machine side power/gas plug fits Lorch/Merkle with 2 O-rings
29002004	Surcharge: machine side power/gas plug fits Fronius with 1 O-ring
29002006	Surcharge: machine side power/gas plug fits Dalex with 1 O-ring
29002107	Surcharge: machine side power/gas plug fits Oerlikon with 1 O-ring
29002002	Surcharge: machine side power/gas plug fits Lorch SK35 + gas-nipple
29000112	Surcharge: machine side fits ESAB central adapter, 4 pins installed at position 3,4,5,6
poti2901	Surcharge: 1 button with additional potentiometer
ud290001	Surcharge: 4 switches > up / down

Please note that there might be additional charges for special control line plugs. See appendix D.

1	90591001	Torch body 9-TW
2	90691001	Torch body 9F-TW neck flexible (FLEX)
3	90791001	Torch body with valve 9V-TW
4	90891001	Torch body with valve 9FV-TW neck flexible (FLEX)
5	90789001	Rotary valve TW complete with O-rings
N.i.	17389013	O-Ring ID3-W1,5mm fits rotary valve TW inside (material hepthon 951)
N.i.	17389012	O-Ring ID4,6-W2mm fits rotary valve TW outside (material hepthon 951)
6	18050002	Ignition insulating hose L75mm / ID39mm down to ID13mm

11.1	91914601	Forma TIG handle with screws, ball joint, without modular switch unit
11.2	91914602	Forma screw for handle
11.3	91914603	Forma hose bracket with ball joint ID21,5mm (also fits MG-handle)
11.4	91914611	Forma modular switch unit: 1 button with connecting adapter
11.5	91914621	Forma modular switch unit: 2 buttons with connecting adapter

Welding-torch TIG gas-cooled**110A at 100% duty cycle (DC) - 95A at 100% duty cycle (AC)**

Art.-No.		
11.6	91914631	Forma modular switch unit: 1 button + potentiometer (10k) with connecting adapter
11.7	91914641	Forma modular switch unit: 2 buttons + up/down (4 switches) with connecting adapter
11.8	91914651	Forma connecting adapter fits control line to modular switch unit
N.i.	91914661	Forma switch module safety nipple
12.1	91914061	MG-handle with ball joint, push-button, 2 return springs, 2 microswitches and 4 cylindrical pins
12.2	91914033	MG-handle fits TW valve torch
13	91914421	MG-tapping screw
14	91915002	MG-push button
16	91914121	MG-microswitch
17	91914221	MG-return spring
18	91914321	MG-cylindrical pin
19	91915001	MG-hose bracket without ball joint ID19,5mm
20	17942403	Power cable 25mm ² 9/17-TW / 4m fits power/gas plugs + power gas junction (pgj)
20	17942803	Power cable 25mm ² 9/17-TW / 8m fits power/gas plugs + power gas junction (pgj)
21	17942402	Power cable 25mm ² 9/17-TW / 4m with SK25 or SK35 <--- please state!
21	17942802	Power cable 25mm ² 9/17-TW / 8m with SK25 or SK35 <--- please state!
22	17942404	Power cable 25mm ² 9/17-TW / 4m fits EURO central adapter (OT-M10x1)
22	17942804	Power cable 25mm ² 9/17-TW / 8m fits EURO central adapter (OT-M10x1)
23.3	22089056	TIG-Power cable connector plugable ID7,2mm fits 25mm ² for power/gas plugs + pgj
23.4	22089053	TIG-Power cable connector OT-M10x1 ID7,2mm fits 25mm ²
Reel goods:		
Prices are per meter and only applicable for purchasing of complete rolls		
24	41500001	Meter ST 70 PVC hose ID4,0-W1,5mm black for gas (100m)
N.i.	91902701	Meter control line 3x0,34mm ² shielded black (100m)
N.i.	91902711	Meter control line 3x0,5mm ² red (100m)
25	91902721	Meter control line 5x0,25mm ² grey (100m)
26	20150002	Meter neoprene protective hose ID20mm black (40m)
N.i.	91915004	Leather protective hose ID22mm / 1 meter long
N.i.	91915007	Leather protective hose ID22mm / 1 meter long with ball joint and hose connector
N.i.	91915003	Hose connector leather protective hose / protection hose ID19,5mm
33	91918201	Powercable-plug SK-25 bayonet connection AD8mm
33	91918301	Powercable-plug SK-35 bayonet connection AD13mm
34	91901501	Coupling nut IT-G1/4"
N.i.	91901211	Hose connector 4mm fits coupling nut R1/4"
37	91904101	Plug 3-poles Tuchel with bayonet-catch
37	91904111	Plug 5-poles Tuchel with bayonet-catch
More control line plugs see appendix D		
39	91918521	TIG power gas junction (pgj) with connection: IT-G1/8"
39	91918522	TIG power gas junction (pgj) with connection: IT-G1/4"
39	91918523	TIG power gas junction (pgj) with connection: IT-G3/8"
N.i.	91918551	Attachment screw (plastic) M5x12mm for power gas junction (pgj)

Welding-torch TIG gas-cooled**110A at 100% duty cycle (DC) - 95A at 100% duty cycle (AC)**

Art.-No.		
N.i.	91918552	3 grommets for attachment screws M5x12mm power gas junction (pgj)
N.i.	91918542	Section of insulating-hose ID35-L80mm power gas junction (pgj)
39.2	91918541	TIG spring socket small power gas junction (pgj)
39.4	91918531	Cable support spring L125mm for power gas junction (pgj)
40	91900701	Terminal nut insulated fits EURO central adapter
41	91900122	TIG central adapter EURO (fits separate lines)
42	91900301	TIG central adapter identical ESAB, 4 contact pins at position 3,4,5,6
42.1	91918561	TIG power gas junction (pgj) fits ESAB central adapter
43	91900901	Coupling nut IT-M10x1 (rounded edges) fits EURO central adapter
44	9190411n	Power/gas plug fits Lorch / Merkle with 2 O-rings / power connection like pgj
44.1	81600001	O-ring ID8-W1,6mm fits Lorch/Merkle
45	91918326	Power/gas plug fits Fronius with 1 O-ring / power connection like pgj
45.1	62190001	O-ring ID6,2-W1,9mm fits Fronius
46	9190416e	Power/gas plug fits Dalex with 1 O-ring / power connection like pgj
46.1	63240001	O-ring ID6,3-W2,4mm fits Dalex
47	9190422n	Power/gas plug fits Oerlikon with 1 O-ring / power connection like pgj
47.1	60717801	O-ring ID6,07-W1,78mm fits Oerlikon
48	9190421n	Power/gas plug fits Lorch Sk35 + gas-nipple / power connection like pgj
48.1	91900801	O-ring ID4-W1mm fits gas-nipple EURO central adapter
N.i.	91900552	TIG cable support long (like MIG-MAG) with screws fits ESAB central adapter
N.i.	91900554	Attachment screw M4x8mm fits ESAB central adapter
49	91900556	TIG cable support short with screws (fits gas-cooled)
N.i.	91920702	Screw M3x11,5mm for Ratio/Industry/RAUCH handle and cable support
N.i.	91920703	M3 mounting socket for Ratio/Industry/RAUCH handle and cable support
N.i.	91900602	Screw M4x6mm for TIG cable support short
49.1	91901012	Reduction-eyelet (rubber) from ID10,5mm to ID5mm fits TIG cable support short
50	91912801	Spring-socket EURO central adapter
51	91912601	Cable support spring fits EURO / ESAB central adapter
60	20091321	Holch back cap long 9-20 41V24/41V24-D
61	20091311	Holch back cap medium 9-20 41V35/41V35-D
62	20091301	Holch back cap short 9-20 41V33/41V33-D
63	20089001	O-ring ID4,6-W2mm for back cap
70	20961002	Collet body 9-20 / 1,0 13N26
70	20961602	Collet body 9-20 / 1,6 13N27
71	20961011	Gas lens 9-20 / 1,0 45V42
71	20961611	Gas lens 9-20 / 1,6 45V43
72-M	20961031	Gas lens medium 9-20 / 1,0
72-M	20961631	Gas lens medium 9-20 / 1,6
72	20961021	Jumbo gas lens 9-20 / 1,0 45V0204S
72	20961621	Jumbo gas lens 9-20 / 1,6 45V116S

Welding-torch TIG gas-cooled**110A at 100% duty cycle (DC) - 95A at 100% duty cycle (AC)**

Art.-No.					
		Brazen collets L-25mm suitable equipment line (A) standard collet body suitable equipment line (B) gas lens			
75	20102502	Collet L25mm 9-20 / 1,0	13N21		
75	20162502	Collet L25mm 9-20 / 1,6	13N22		
		Brazen collets L-40mm suitable equipment line (C) gas lens midsize suitable equipment line (D) gas lens jumbo			
76	20104011	Collet L40mm 9-20 / 1,0	13N21L		
76	20164011	Collet L40mm 9-20 / 1,6	13N22L		
78	20089011	PTFE-isolator gasket 9-20			
79-M	20089031	PTFE-gas lens isolator medium size 9-20			
79	20089021	PTFE-gas lens isolator Jumbo 9-20	54N63-20		
		Ceramic gas nozzles in different lengths suitable equipment line (A) standard collet body			
80	20930401	Ceramic gas nozzle L30mm / Gr. 4	13N08	(pu=10pieces)	
80	20930501	Ceramic gas nozzle L30mm / Gr. 5	13N09	(pu=10pieces)	
80	20930601	Ceramic gas nozzle L30mm / Gr. 6	13N10	(pu=10pieces)	
80	20930701	Ceramic gas nozzle L30mm / Gr. 7	13N11	(pu=10pieces)	
80	20930801	Ceramic gas nozzle L30mm / Gr. 8	13N12	(pu=10pieces)	
80	20930101	Ceramic gas nozzle L30mm / Gr.10	13N13	(pu=10pieces)	
N.i.	20930304	Ceramic gas nozzle L48mm / Gr. 3	796F70	(pu=10pieces)	
N.i.	20930404	Ceramic gas nozzle L48mm / Gr. 4	796F71	(pu=10pieces)	
N.i.	20930504	Ceramic gas nozzle L48mm / Gr. 5	796F72	(pu=10pieces)	
N.i.	20930604	Ceramic gas nozzle L48mm / Gr. 6	796F73	(pu=10pieces)	
N.i.	20930306	Ceramic gas nozzle L63mm / Gr. 3	796F74	(pu=10pieces)	
N.i.	20930406	Ceramic gas nozzle L63mm / Gr. 4	796F75	(pu=10pieces)	
N.i.	20930506	Ceramic gas nozzle L63mm / Gr. 5	796F76	(pu=10pieces)	
N.i.	20930606	Ceramic gas nozzle L63mm / Gr. 6	796F77	(pu=10pieces)	
N.i.	20930408	Ceramic gas nozzle L89mm / Gr. 4	796F79	(pu=10pieces)	
		Ceramic gas nozzles in different lengths suitable equipment line (B) gas lens			
90	20931401	Ceramic gas nozzle for gas lens L25,5mm 9-20 / Gr.4	53N58	(pu=10pieces)	
90	20931501	Ceramic gas nozzle for gas lens L25,5mm 9-20 / Gr.5	53N59	(pu=10pieces)	
90	20931601	Ceramic gas nozzle for gas lens L25,5mm 9-20 / Gr.6	53N60	(pu=10pieces)	
90	20931701	Ceramic gas nozzle for gas lens L25,5mm 9-20 / Gr.7	53N61	(pu=10pieces)	
90	20931801	Ceramic gas nozzle for gas lens L25,5mm 9-20 / Gr.8	53N61-S	(pu=10pieces)	
N.i.	20931404	Ceramic gas nozzle for gas lens L35mm 9-20 / Gr.4	53N58L	(pu=10pieces)	
N.i.	20931504	Ceramic gas nozzle for gas lens L35mm 9-20 / Gr.5	53N59L	(pu=10pieces)	
N.i.	20931604	Ceramic gas nozzle for gas lens L35mm 9-20 / Gr.6	53N60L	(pu=10pieces)	
N.i.	20931704	Ceramic gas nozzle for gas lens L35mm 9-20 / Gr.7	53N61L	(pu=10pieces)	
N.i.	20931804	Ceramic gas nozzle for gas lens L35mm 9-20 / Gr.8	53N61SL	(pu=10pieces)	
N.i.	20931406	Ceramic gas nozzle for gas lens L72mm 9-20 / Gr.4	53N58XL	(pu=10pieces)	

Welding-torch TIG gas-cooled**110A at 100% duty cycle (DC) - 95A at 100% duty cycle (AC)**

Art.-No.		
N.i.	20931506	Ceramic gas nozzle for gas lens L72mm 9-20 / Gr.5 53N59XL (pu=10pieces)
N.i.	20931606	Ceramic gas nozzle for gas lens L72mm 9-20 / Gr.6 53N60XL (pu=10pieces)
N.i.	20931706	Ceramic gas nozzle for gas lens L72mm 9-20 / Gr.7 53N61XL (pu=10pieces)
N.i.	20931806	Ceramic gas nozzle for gas lens L72mm 9-20 / Gr.8 53N61XL (pu=10pieces)
90-C	20930006	Ceramic nozzle for gas lens Kir Royal 9-20 / fits tungsten electrodes up to 2,4mm
90-C	20930016	Ceramic nozzle for gas lens Kir Royal 9-20 / fits tungsten electrode 3,2mm

**Ceramic gas nozzles in different lengths
suitable equipment line (C) midsize gas lens**

90-M	22093041	Gas nozzle for gas lens L42mm / Gr.4 54N18 (pu=10pieces)
90-M	22093051	Gas nozzle for gas lens L42mm / Gr.5 54N17 (pu=10pieces)
90-M	22093061	Gas nozzle for gas lens L42mm / Gr.6 54N16 (pu=10pieces)
90-M	22093071	Gas nozzle for gas lens L42mm / Gr.7 54N15 (pu=10pieces)
90-M	22093081	Gas nozzle for gas lens L42mm / Gr.8 54N14 (pu=10pieces)
90-M	22093111	Gas nozzle for gas lens L42mm / Gr.11 54N19-11 (pu=10pieces)
90-M	22093121	Gas nozzle for gas lens L42mm / Gr.12 54N19 (pu=10pieces)
N.i.	22093054	Gas nozzle for gas lens L76mm / Gr.5 54N17L (pu=10pieces)
N.i.	22093064	Gas nozzle for gas lens L76mm / Gr.6 54N16L (pu=10pieces)
N.i.	22093074	Gas nozzle for gas lens L76mm / Gr.7 54N15L (pu=10pieces)
N.i.	22093084	Gas nozzle for gas lens L76mm / Gr.8 54N14L (pu=10pieces)

**Ceramic gas nozzles jumbo in different lengths
suitable equipment line (D) gas lens jumbo**

95	22093066	Jumbo gas nozzle L48mm / Gr.6 57N75 (pu=10pieces)
95	22093086	Jumbo gas nozzle L48mm / Gr.8 57N74 (pu=10pieces)
95	22093106	Jumbo gas nozzle L48mm / Gr.10 53N88 (pu=10pieces)
95	22093126	Jumbo gas nozzle L48mm / Gr.12 53N87 (pu=10pieces)
N.i.	22093067	Jumbo gas nozzle L73mm / Gr.6 57N75L (pu=10pieces)
N.i.	22093087	Jumbo gas nozzle L73mm / Gr.8 57N74L (pu=10pieces)
N.i.	22093107	Jumbo gas nozzle L73mm / Gr.10 53N88L (pu=10pieces)
N.i.	22093127	Jumbo gas nozzle L73mm / Gr.12 53N87L (pu=10pieces)

Top quality tungsten electrodes in 9 different qualities, see appendix A.

Torch AS 17-TW gas-cooled



Holch Schweißbrenner GmbH
Bühlstraße 14
D-57080 Siegen

Phone: +49(0)271 387860-11
Telefax: +49(0)271 387860-29
E-Mail: info@holch-siegen.de
Web: www.holch-siegen.de



AS 17-TW gas-cooled

140 Ampere at 100% duty cycle (DC) - 125 Ampere at 100% duty cycle (AC)

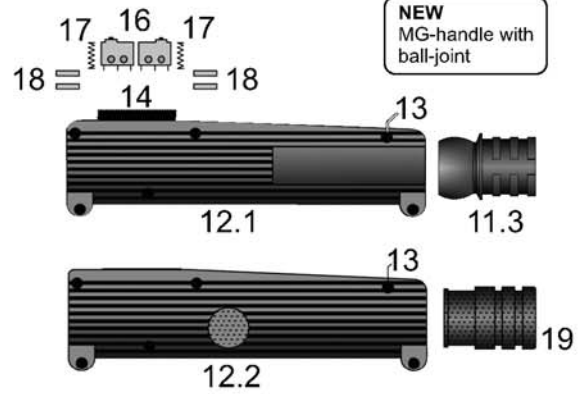
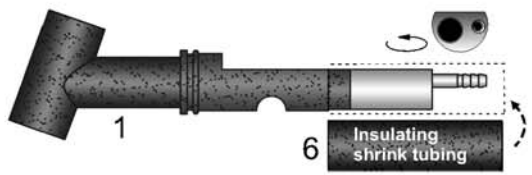

Forma WIG-handle with ball joint and different modular switch units

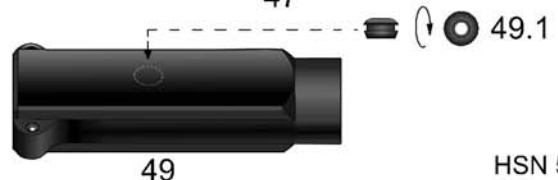
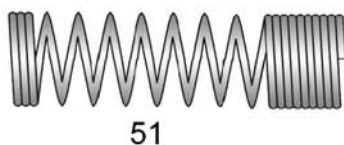
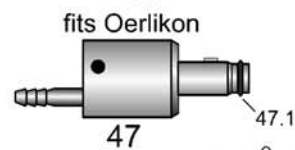
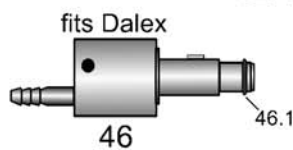
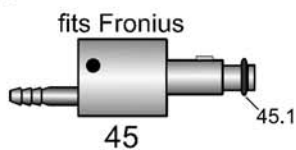
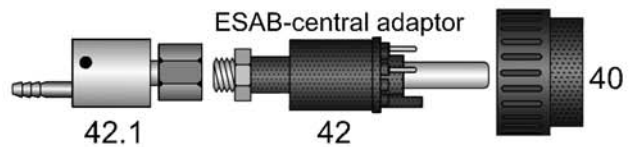
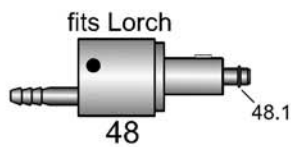
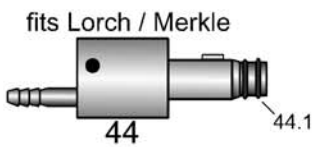
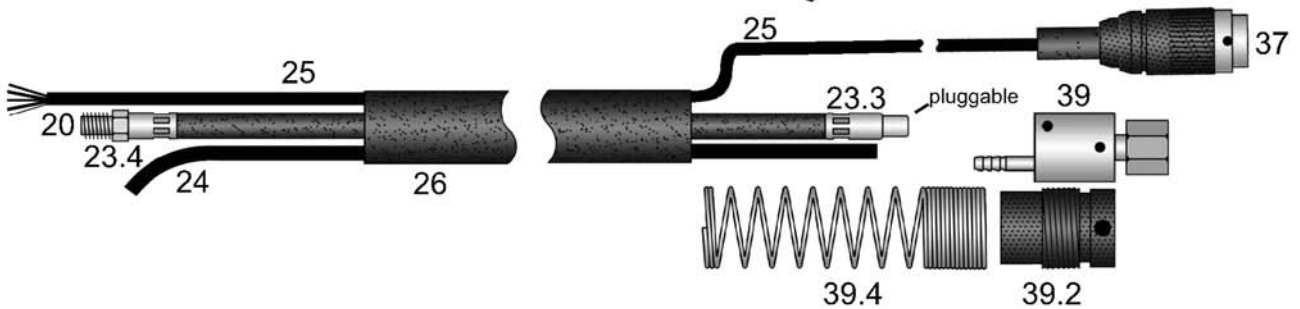
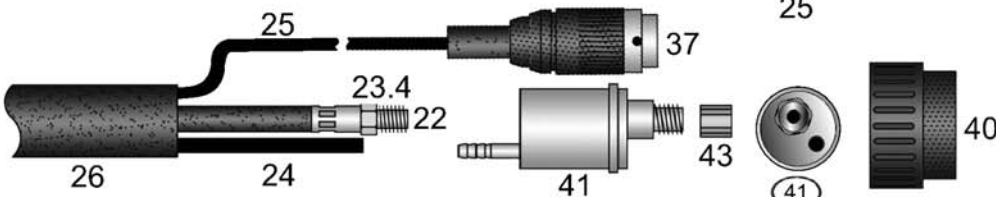
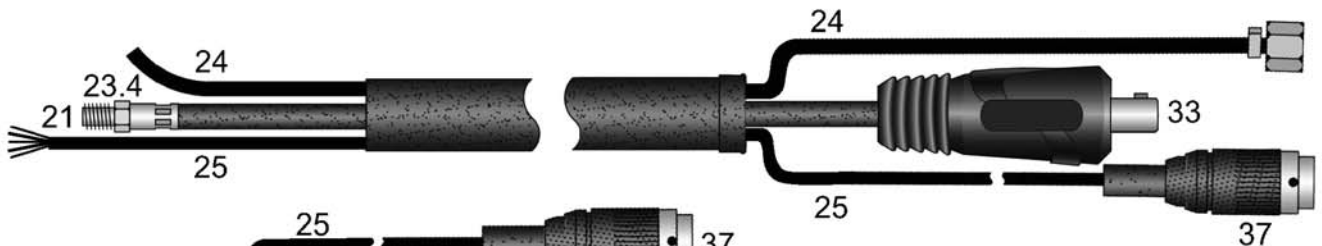

HSN 524



Equipment: **A** standard
B gas lens
D gas lens jumbo

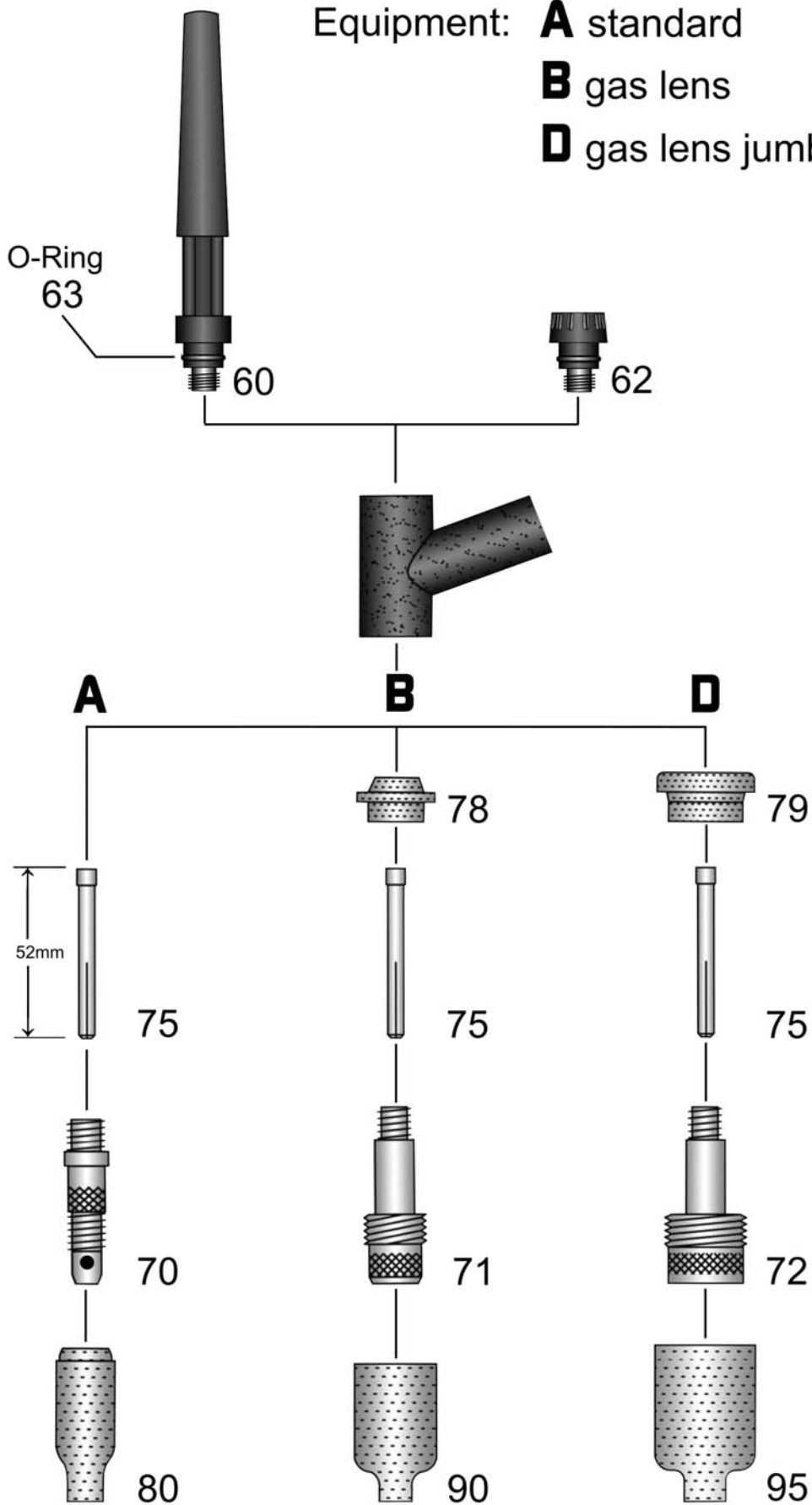

Welding-torch TIG gas-cooled**140A at 100% duty cycle (DC) - 125A at 100% duty cycle (AC)****Art.-No.**

Torches with first meter leather hose. Prices without leather on request. Machine side separate connections.

Torches and cable assemblies can be produced in excess lengths. Please find the different options and surcharges in the attachment "Custom made products" appendix C. We produce torches for more than 40 different brands of machines with different connection systems.

17800401 Torch AS 17-TW / 4m 25mm²17800801 Torch AS 17-TW / 8m 25mm²17130401 Valve torch AS 17V-TW / 4m 25mm²17130801 Valve torch AS 17V-TW / 8m 25mm²

TIG-spare cable assemblies in different qualities, machine side with separate connections and Tichel plug, or, if ordered so, with the following connection systems:

wig92401 TIG-spare cable assembly gas-cooled 4m - please state desired design!

wig92801 TIG-spare cable assembly gas-cooled 8m - please state desired design!

The following surcharges for machine side connections are only to find prices quickly. Please use our catalogue "TIG machine side connections" to find a "T" number which identifies a machine side connection system completely.

29000101 Surcharge: machine side with EURO central adapter

29002005 Surcharge: machine side power/gas plug fits Lorch/Merkle with 2 O-rings

29002004 Surcharge: machine side power/gas plug fits Fronius with 1 O-ring

29002006 Surcharge: machine side power/gas plug fits Dalex with 1 O-ring

29002107 Surcharge: machine side power/gas plug fits Oerlikon with 1 O-ring

29002002 Surcharge: machine side power/gas plug fits Lorch SK35 + gas-nipple

29000112 Surcharge: machine side fits ESAB central adapter, 4 pins installed at position 3,4,5,6

poti2901 Surcharge: 1 button with additional potentiometer

ud290001 Surcharge: 4 switches > up / down

Please note that there might be additional charges for special control line plugs. See appendix D.

1 17891001 Torch body AS 17-TW

3 17139101 Torch body with valve AS 17V-TW

5 90789001 Rotary valve TW complete with O-rings

N.i. 17389013 O-Ring ID3-W1,5mm fits rotary valve TW inside (material hepthon 951)

N.i. 17389012 O-Ring ID4,6-W2mm fits rotary valve TW outside (material hepthon 951)

6 18050002 Ignition insulating hose L75mm / ID39mm down to ID13mm

11.1 91914601 Forma TIG handle with screws, ball joint, without modular switch unit

11.2 91914602 Forma screw for handle

11.3 91914603 Forma hose bracket with ball joint ID21,5mm (also fits MG-handle)

11.4 91914611 Forma modular switch unit: 1 button with connecting adapter

11.5 91914621 Forma modular switch unit: 2 buttons with connecting adapter

11.6 91914631 Forma modular switch unit: 1 button + potentiometer (10k) with connecting adapter

11.7 91914641 Forma modular switch unit: 2 buttons + up/down (4 switches) with connecting adapter

11.8 91914651 Forma connecting adapter fits control line to modular switch unit

N.i. 91914661 Forma switch module safety nipple

12.1 91914061 MG-handle with ball joint, push-button, 2 return springs, 2 microswitches and 4 cylindrical pins

12.2 91914033 MG-handle fits TW valve torch

13 91914421 MG-tapping screw

Welding-torch TIG gas-cooled**140A at 100% duty cycle (DC) - 125A at 100% duty cycle (AC)**

Art.-No.		
14	91915002	MG-push button
16	91914121	MG-microswitch
17	91914221	MG-return spring
18	91914321	MG-cylindrical pin
19	91915001	MG-hose bracket without ball joint ID19,5mm
20	17942403	Power cable 25mm ² 9/17-TW / 4m fits power/gas plugs + power gas junction (pgj)
20	17942803	Power cable 25mm ² 9/17-TW / 8m fits power/gas plugs + power gas junction (pgj)
21	17942402	Power cable 25mm ² 9/17-TW / 4m with SK25 or SK35 <--- please state!
21	17942802	Power cable 25mm ² 9/17-TW / 8m with SK25 or SK35 <--- please state!
22	17942404	Power cable 25mm ² 9/17-TW / 4m fits EURO central adapter (OT-M10x1)
22	17942804	Power cable 25mm ² 9/17-TW / 8m fits EURO central adapter (OT-M10x1)
23.3	22089056	TIG-Power cable connector plugable ID7,2mm fits 25mm ² for power/gas plugs + pgj
23.4	22089053	TIG-Power cable connector OT-M10x1 ID7,2mm fits 25mm ²
Reel goods:		
Prices are per meter and only applicable for purchasing of complete rolls		
24	41500001	Meter ST 70 PVC hose ID4,0-W1,5mm black for gas (100m)
N.i.	91902701	Meter control line 3x0,34mm ² shielded black (100m)
N.i.	91902711	Meter control line 3x0,5mm ² red (100m)
25	91902721	Meter control line 5x0,25mm ² grey (100m)
26	20150002	Meter neoprene protective hose ID20mm black (40m)
N.i.	91915004	Leather protective hose ID22mm / 1 meter long
N.i.	91915007	Leather protective hose ID22mm / 1 meter long with ball joint and hose connector
N.i.	91915003	Hose connector leather protective hose / protection hose ID19,5mm
33	91918201	Powercable-plug SK-25 bayonet connection AD8mm
33	91918301	Powercable-plug SK-35 bayonet connection AD13mm
34	91901501	Coupling nut IT-G1/4"
N.i.	91901211	Hose connector 4mm fits coupling nut R1/4"
37	91904101	Plug 3-poles Tuchel with bayonet-catch
37	91904111	Plug 5-poles Tuchel with bayonet-catch
More control line plugs see appendix D		
39	91918521	TIG power gas junction (pgj) with connection: IT-G1/8"
39	91918522	TIG power gas junction (pgj) with connection: IT-G1/4"
39	91918523	TIG power gas junction (pgj) with connection: IT-G3/8"
N.i.	91918551	Attachment screw (plastic) M5x12mm for power gas junction (pgj)
N.i.	91918552	3 grommets for attachment screws M5x12mm power gas junction (pgj)
N.i.	91918542	Section of insulating-hose ID35-L80mm power gas junction (pgj)
39.2	91918541	TIG spring socket small power gas junction (pgj)
39.4	91918531	Cable support spring L125mm for power gas junction (pgj)
40	91900701	Terminal nut insulated fits EURO central adapter
41	91900122	TIG central adapter EURO (fits separate lines)
42	91900301	TIG central adapter identical ESAB, 4 contact pins at position 3,4,5,6
42.1	91918561	TIG power gas junction (pgj) fits ESAB central adapter

Welding-torch TIG gas-cooled**140A at 100% duty cycle (DC) - 125A at 100% duty cycle (AC)**

Art.-No.		
43	91900901	Coupling nut IT-M10x1 (rounded edges) fits EURO central adapter
44	9190411n	Power/gas plug fits Lorch / Merkle with 2 O-rings / power connection like pgj
44.1	81600001	O-ring ID8-W1,6mm fits Lorch/Merkle
45	91918326	Power/gas plug fits Fronius with 1 O-ring / power connection like pgj
45.1	62190001	O-ring ID6,2-W1,9mm fits Fronius
46	9190416e	Power/gas plug fits Dalex with 1 O-ring / power connection like pgj
46.1	63240001	O-ring ID6,3-W2,4mm fits Dalex
47	9190422n	Power/gas plug fits Oerlikon with 1 O-ring / power connection like pgj
47.1	60717801	O-ring ID6,07-W1,78mm fits Oerlikon
48	9190421n	Power/gas plug fits Lorch Sk35 + gas-nipple / power connection like pgj
48.1	91900801	O-ring ID4-W1mm fits gas-nipple EURO central adapter
N.i.	91900552	TIG cable support long (like MIG-MAG) with screws fits ESAB central adapter
N.i.	91900554	Attachment screw M4x8mm fits ESAB central adapter
49	91900556	TIG cable support short with screws (fits gas-cooled)
N.i.	91920702	Screw M3x11,5mm for Ratio/Industry/RAUCH handle and cable support
N.i.	91920703	M3 mounting socket for Ratio/Industry/RAUCH handle and cable support
o.A.	91900602	Screw M4x6mm for TIG cable support short
49.1	91901012	Reduction-eyelet (rubber) from ID10,5mm to ID5mm fits TIG cable support short
50	91912801	Spring-socket EURO central adapter
51	91912601	Cable support spring fits EURO / ESAB central adapter
60	17091311	Holch back cap long (german version with black O-ring) AS17-AS18-ABL220 57Y02-D
62	17091301	Holch back cap short (german version with black O-ring) AS17-AS18-ABL220 57Y04-D
63	17089011	O-ring black ID9-W2,5mm for back cap
70	17961002	Collet body 17-18-26-220 / 1,0 10N30
70	17961602	Collet body 17-18-26-220 / 1,6 10N31
70	17962402	Collet body 17-18-26-220 / 2,4 10N32
71	17961011	Gas lens 17-18-26-220 / 1,0 45V24
71	17961611	Gas lens 17-18-26-220 / 1,6 45V25
71	17962411	Gas lens 17-18-26-220 / 2,4 45V26
72	17961021	Jumbo gas lens 17-18-26-220 / 1,0 45V0204
72	17961621	Jumbo gas lens 17-18-26-220 / 1,6 45V116
72	17962421	Jumbo gas lens 17-18-26-220 / 2,4 45V64
Brazen collets L-52mm		
suitable equipment line (A) standard collet body		
suitable equipment line (B) gas lens		
suitable equipment line (D) gas lens jumbo		
75	17105202	Collet L52mm AS17-AS18-ABL220 / 1,0 10N22-D
75	17165202	Collet L52mm AS17-AS18-ABL220 / 1,6 10N23-D
75	17245202	Collet L52mm AS17-AS18-ABL220 / 2,4 10N24-D
78	17089021	PTFE-Gas-lens insulator 17-18-26-220 54N01
79	17089031	PTFE-Gas-lens insulator Jumbo 17-18-26-220 54N63

Welding-torch TIG gas-cooled**140A at 100% duty cycle (DC) - 125A at 100% duty cycle (AC)****Art.-No.****Ceramic gas nozzles in different lengths
suitable equipment line (A) standard collet body**

80	17930401	Ceramic gas nozzle L47mm	17-18-26-220 / Gr.4	10N50	(pu=10pieces)
80	17930501	Ceramic gas nozzle L47mm	17-18-26-220 / Gr.5	10N49	(pu=10pieces)
80	17930601	Ceramic gas nozzle L47mm	17-18-26-220 / Gr.6	10N48	(pu=10pieces)
80	17930701	Ceramic gas nozzle L47mm	17-18-26-220 / Gr.7	10N47	(pu=10pieces)
80	17930801	Ceramic gas nozzle L47mm	17-18-26-220 / Gr.8	10N46	(pu=10pieces)
80	17930101	Ceramic gas nozzle L47mm	17-18-26-220 / Gr.10	10N45	(pu=10pieces)
80	17930121	Ceramic gas nozzle L47mm	17-18-26-220 / Gr.12	10N44	(pu=10pieces)

N.i.	17930404	Ceramic gas nozzle L76mm	17-18-26-220 / Gr.4	10N50L	(pu=10pieces)
N.i.	17930504	Ceramic gas nozzle L76mm	17-18-26-220 / Gr.5	10N49L	(pu=10pieces)
N.i.	17930604	Ceramic gas nozzle L76mm	17-18-26-220 / Gr.6	10N48L	(pu=10pieces)
N.i.	17930704	Ceramic gas nozzle L76mm	17-18-26-220 / Gr.7	10N47L	(pu=10pieces)

**Ceramic gas nozzles in different lengths
suitable equipment line (B) gas lens**

90	22093041	Gas nozzle for gas lens L42mm	/ Gr.4	54N18	(pu=10pieces)
90	22093051	Gas nozzle for gas lens L42mm	/ Gr.5	54N17	(pu=10pieces)
90	22093061	Gas nozzle for gas lens L42mm	/ Gr.6	54N16	(pu=10pieces)
90	22093071	Gas nozzle for gas lens L42mm	/ Gr.7	54N15	(pu=10pieces)
90	22093081	Gas nozzle for gas lens L42mm	/ Gr.8	54N14	(pu=10pieces)
90	22093111	Gas nozzle for gas lens L42mm	/ Gr.11	54N19-11	(pu=10pieces)
90	22093121	Gas nozzle for gas lens L42mm	/ Gr.12	54N19	(pu=10pieces)

N.i.	22093054	Gas nozzle for gas lens L76mm	/ Gr.5	54N17L	(pu=10pieces)
N.i.	22093064	Gas nozzle for gas lens L76mm	/ Gr.6	54N16L	(pu=10pieces)
N.i.	22093074	Gas nozzle for gas lens L76mm	/ Gr.7	54N15L	(pu=10pieces)
N.i.	22093084	Gas nozzle for gas lens L76mm	/ Gr.8	54N14L	(pu=10pieces)

**Ceramic gas nozzles jumbo in different lengths
suitable equipment line (D) gas lens jumbo**

95	22093066	Jumbo gas nozzle L48mm	/ Gr.6	57N75	(pu=10pieces)
95	22093086	Jumbo gas nozzle L48mm	/ Gr.8	57N74	(pu=10pieces)
95	22093106	Jumbo gas nozzle L48mm	/ Gr.10	53N88	(pu=10pieces)
95	22093126	Jumbo gas nozzle L48mm	/ Gr.12	53N87	(pu=10pieces)

N.i.	22093067	Jumbo gas nozzle L73mm	/ Gr.6	57N75L	(pu=10pieces)
N.i.	22093087	Jumbo gas nozzle L73mm	/ Gr.8	57N74L	(pu=10pieces)
N.i.	22093107	Jumbo gas nozzle L73mm	/ Gr.10	53N88L	(pu=10pieces)
N.i.	22093127	Jumbo gas nozzle L73mm	/ Gr.12	53N87L	(pu=10pieces)

Top quality tungsten electrodes in 9 different qualities, see appendix A.

Torch SR 17-TW gas-cooled



Holch Schweißbrenner GmbH
Bühlstraße 14
D-57080 Siegen

Phone: +49(0)271 387860-11
Telefax: +49(0)271 387860-29
E-Mail: info@holch-siegen.de
Web: www.holch-siegen.de



SR 17-TW gas-cooled

140 Ampere at 100% duty cycle (DC)

- 125 Ampere at 100% duty cycle (AC)

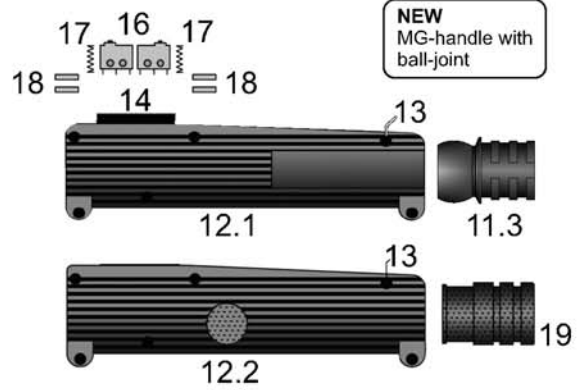
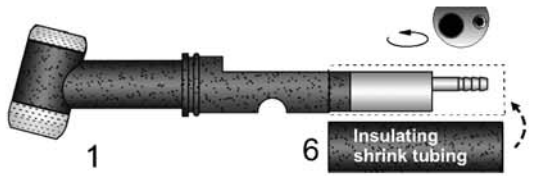

NEW
MG-handle with
ball-joint

Forma WIG-handle with ball joint and different modular switch units

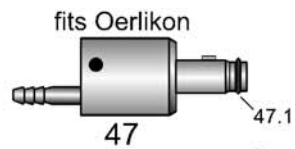
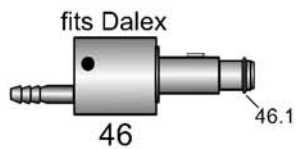
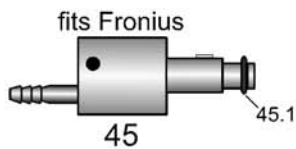
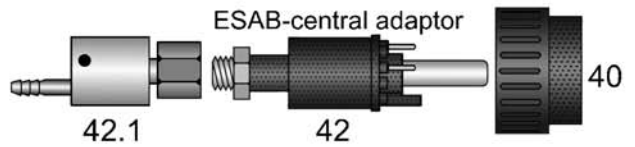
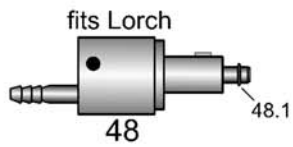
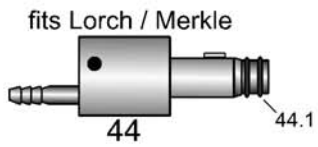
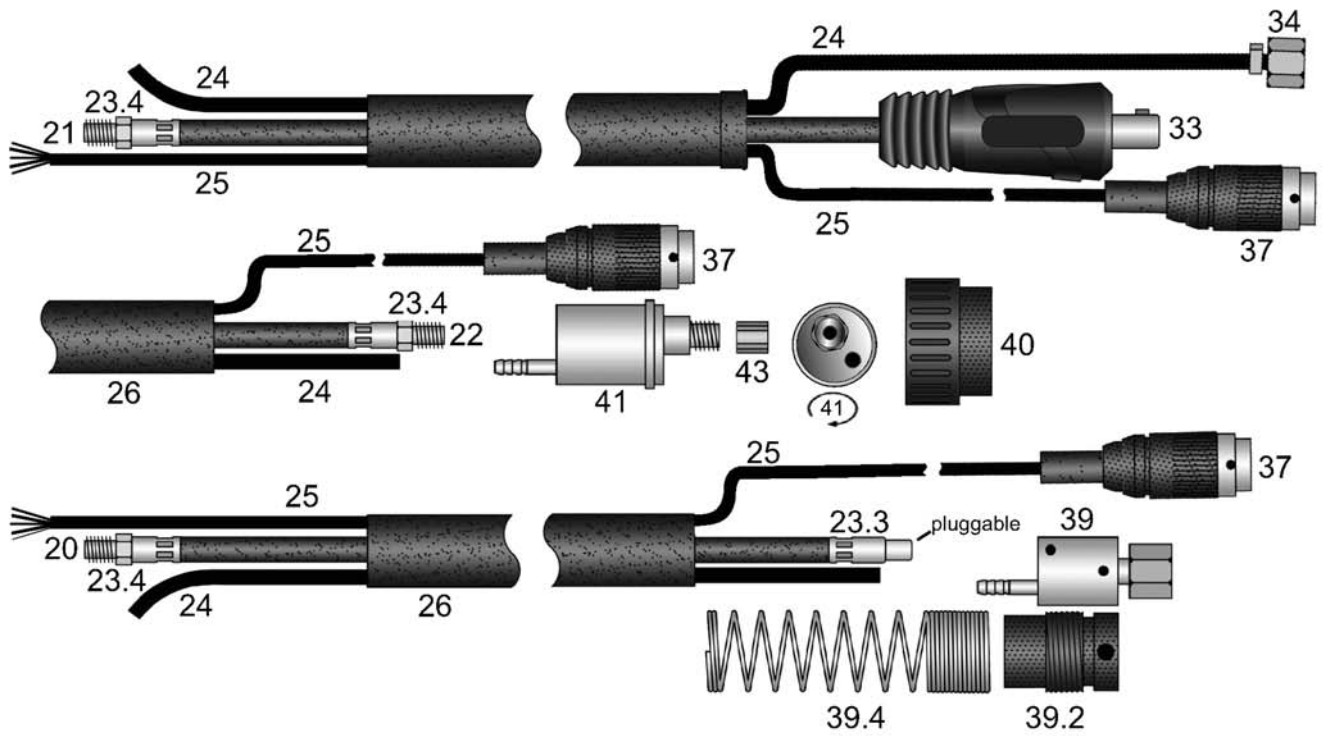

HSN 529

SR 17 - TW gas-cooled spare parts



Equipment: **A** standard
B gas lens
D gas lens jumbo
E gas lens mini
F standard mini

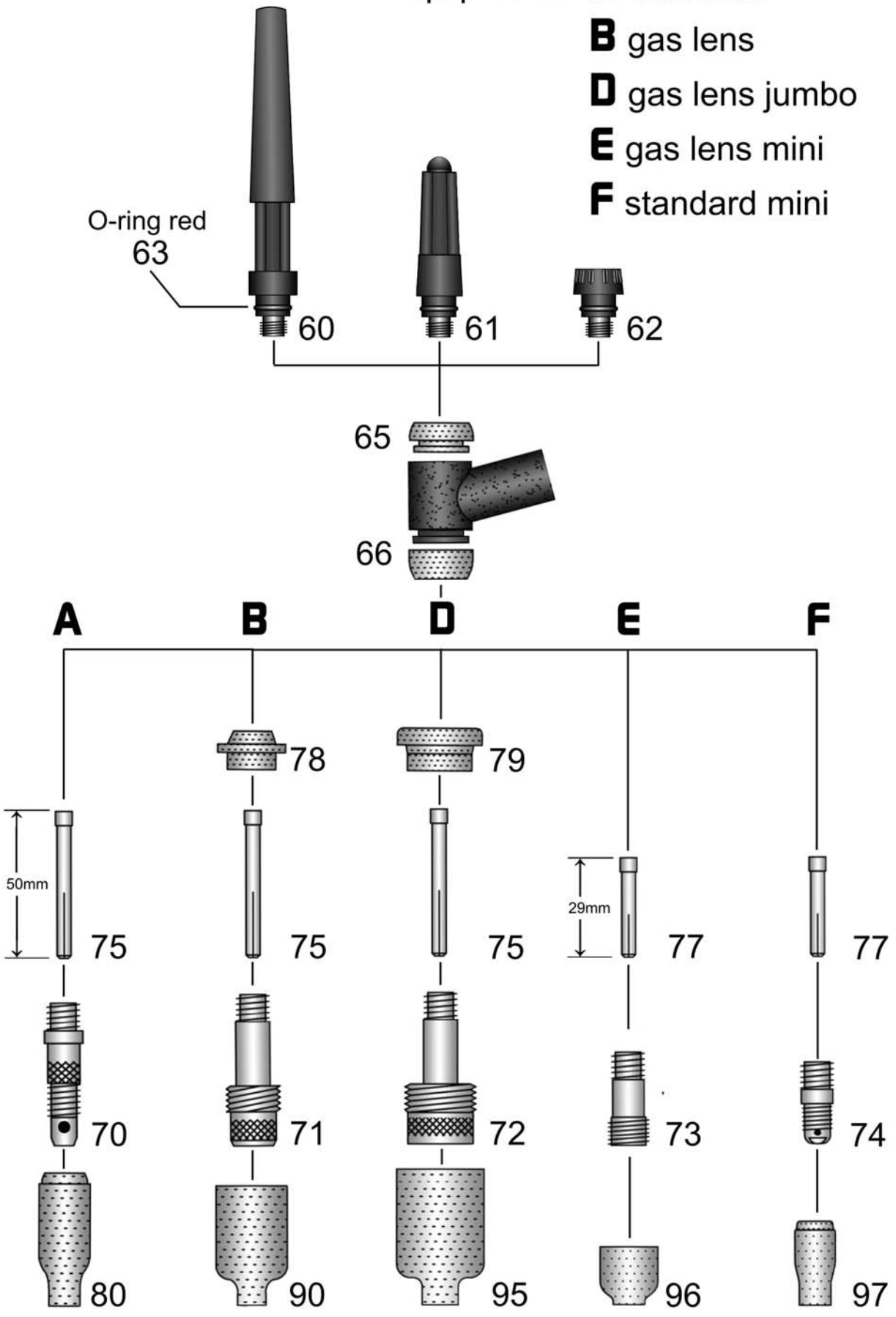

HSN 111

Welding-torch TIG gas-cooled**140A at 100% duty cycle (DC) - 125A at 100% duty cycle (AC)****Art.-No.**

Torches with first meter leather hose. Prices without leather on request. Machine side separate connections.

Torches and cable assemblies can be produced in excess lengths. Please find the different options and surcharges in the attachment "Custom made products" appendix C. We produce torches for more than 40 different brands of machines with different connection systems.

17900401 Torch SR 17-TW / 4m 25mm²17900801 Torch SR 17-TW / 8m 25mm²17140401 Valve torch SR 17V-TW / 4m 25mm²17140801 Valve torch SR 17V-TW / 8m 25mm²

TIG-spare cable assemblies in different qualities, machine side with separate connections and Tichel plug, or, if ordered so, with the following connection systems:

wig92401 TIG-spare cable assembly gas-cooled 4m - please state desired design!

wig92801 TIG-spare cable assembly gas-cooled 8m - please state desired design!

The following surcharges for machine side connections are only to find prices quickly. Please use our catalogue "TIG machine side connections" to find a "T" number which identifies a machine side connection system completely.

29000101 Surcharge: machine side with EURO central adapter

29002005 Surcharge: machine side power/gas plug fits Lorch/Merkle with 2 O-rings

29002004 Surcharge: machine side power/gas plug fits Fronius with 1 O-ring

29002006 Surcharge: machine side power/gas plug fits Dalex with 1 O-ring

29002107 Surcharge: machine side power/gas plug fits Oerlikon with 1 O-ring

29002002 Surcharge: machine side power/gas plug fits Lorch SK35 + gas-nipple

29000112 Surcharge: machine side fits ESAB central adapter, 4 pins installed at position 3,4,5,6

poti2901 Surcharge: 1 button with additional potentiometer

ud290001 Surcharge: 4 switches > up / down

Please note that there might be additional charges for special control line plugs. See appendix D.

1 17991001 Torch body SR 17-TW

3 17149101 Torch body with valve SR 17V-TW

5 90789001 Rotary valve TW complete with O-rings

N.i. 17389013 O-Ring ID3-W1,5mm fits rotary valve TW inside (material hepthon 951)

N.i. 17389012 O-Ring ID4,6-W2mm fits rotary valve TW outside (material hepthon 951)

6 18050002 Ignition insulating hose L75mm / ID39mm down to ID13mm

11.1 91914601 Forma TIG handle with screws, ball joint, without modular switch unit

11.2 91914602 Forma screw for handle

11.3 91914603 Forma hose bracket with ball joint ID21,5mm (also fits MG-handle)

11.4 91914611 Forma modular switch unit: 1 button with connecting adapter

11.5 91914621 Forma modular switch unit: 2 buttons with connecting adapter

11.6 91914631 Forma modular switch unit: 1 button + potentiometer (10k) with connecting adapter

11.7 91914641 Forma modular switch unit: 2 buttons + up/down (4 switches) with connecting adapter

11.8 91914651 Forma connecting adapter fits control line to modular switch unit

N.i. 91914661 Forma switch module safety nipple

12.1 91914061 MG-handle with ball joint, push-button, 2 return springs, 2 microswitches and 4 cylindrical pins

12.2 91914033 MG-handle fits TW valve torch

13 91914421 MG-tapping screw

Welding-torch TIG gas-cooled**140A at 100% duty cycle (DC) - 125A at 100% duty cycle (AC)**

Art.-No.		
14	91915002	MG-push button
16	91914121	MG-microswitch
17	91914221	MG-return spring
18	91914321	MG-cylindrical pin
19	91915001	MG-hose bracket without ball joint ID19,5mm
20	17942403	Power cable 25mm ² 9/17-TW / 4m fits power/gas plugs + power gas junction (pgj)
20	17942803	Power cable 25mm ² 9/17-TW / 8m fits power/gas plugs + power gas junction (pgj)
21	17942402	Power cable 25mm ² 9/17-TW / 4m with SK25 or SK35 <--- please state!
21	17942802	Power cable 25mm ² 9/17-TW / 8m with SK25 or SK35 <--- please state!
22	17942404	Power cable 25mm ² 9/17-TW / 4m fits EURO central adapter (OT-M10x1)
22	17942804	Power cable 25mm ² 9/17-TW / 8m fits EURO central adapter (OT-M10x1)
23.3	22089056	TIG-Power cable connector plugable ID7,2mm fits 25mm ² for power/gas plugs + pgj
23.4	22089053	TIG-Power cable connector OT-M10x1 ID7,2mm fits 25mm ²
Reel goods:		
Prices are per meter and only applicable for purchasing of complete rolls		
24	41500001	Meter ST 70 PVC hose ID4,0-W1,5mm black for gas (100m)
N.i.	91902701	Meter control line 3x0,34mm ² shielded black (100m)
N.i.	91902711	Meter control line 3x0,5mm ² red (100m)
25	91902721	Meter control line 5x0,25mm ² grey (100m)
26	20150002	Meter neoprene protective hose ID20mm black (40m)
N.i.	91915004	Leather protective hose ID22mm / 1 meter long
N.i.	91915007	Leather protective hose ID22mm / 1 meter long with ball joint and hose connector
N.i.	91915003	Hose connector leather protective hose / protection hose ID19,5mm
33	91918201	Powercable-plug SK-25 bayonet connection AD8mm
33	91918301	Powercable-plug SK-35 bayonet connection AD13mm
34	91901501	Coupling nut IT-G1/4"
34	91901211	Hose connector 4mm fits coupling nut R1/4"
37	91904101	Plug 3-poles Tuchel with bayonet-catch
37	91904111	Plug 5-poles Tuchel with bayonet-catch
More control line plugs see appendix D		
39	91918521	TIG power gas junction (pgj) with connection: IT-G1/8"
39	91918522	TIG power gas junction (pgj) with connection: IT-G1/4"
39	91918523	TIG power gas junction (pgj) with connection: IT-G3/8"
N.i.	91918551	Attachment screw (plastic) M5x12mm for power gas junction (pgj)
N.i.	91918552	3 grommets for attachment screws M5x12mm power gas junction (pgj)
N.i.	91918542	Section of insulating-hose ID35-L80mm power gas junction (pgj)
39.2	91918541	TIG spring socket small power gas junction (pgj)
39.4	91918531	Cable support spring L125mm for power gas junction (pgj)
40	91900701	Terminal nut insulated fits EURO central adapter
41	91900122	TIG central adapter EURO (fits separate lines)
42	91900301	TIG central adapter identical ESAB, 4 contact pins at position 3,4,5,6
42.1	91918561	TIG power gas junction (pgj) fits ESAB central adapter

Welding-torch TIG gas-cooled**140A at 100% duty cycle (DC) - 125A at 100% duty cycle (AC)**

Art.-No.		
43	91900901	Coupling nut IT-M10x1 (rounded edges) fits EURO central adapter
44	9190411n	Power/gas plug fits Lorch / Merkle with 2 O-rings / power connection like pgj
44.1	81600001	O-ring ID8-W1,6mm fits Lorch/Merkle
45	91918326	Power/gas plug fits Fronius with 1 O-ring / power connection like pgj
45.1	62190001	O-ring ID6,2-W1,9mm fits Fronius
46	9190416e	Power/gas plug fits Dalex with 1 O-ring / power connection like pgj
46.1	63240001	O-ring ID6,3-W2,4mm fits Dalex
47	9190422n	Power/gas plug fits Oerlikon with 1 O-ring / power connection like pgj
47.1	60717801	O-ring ID6,07-W1,78mm fits Oerlikon
48	9190421n	Power/gas plug fits Lorch Sk35 + gas-nipple / power connection like pgj
48.1	91900801	O-ring ID4-W1mm fits gas-nipple EURO central adapter
N.i.	91900552	TIG cable support long (like MIG-MAG) with screws fits ESAB central adapter
N.i.	91900554	Attachment screw M4x8mm fits ESAB central adapter
49	91900556	TIG cable support short with screws (fits gas-cooled)
N.i.	91920702	Screw M3x11,5mm for Ratio/Industry/RAUCH handle and cable support
N.i.	91920703	M3 mounting socket for Ratio/Industry/RAUCH handle and cable support
o.A.	91900602	Screw M4x6mm for TIG cable support short
49.1	91901012	Reduction-eyelet (rubber) from ID10,5mm to ID5mm fits TIG cable support short
50	91912801	Spring-socket EURO central adapter
51	91912601	Cable support spring fits EURO / ESAB central adapter
60	17191311	Holch back cap long (USA version with red O-ring) SR 17-18-26 57Y02
61	17191322	Import back cap medium (USA version with red O-ring) SR 17-18-26 57Y03
62	17191301	Holch back cap short (USA version with red O-ring) SR 17-18-26 57Y04
63	17189001	O-ring red ID8-W2mm for back cap
65	17289001	PTFE-back-cap gasket ring SR 17-18-26 18-7
66	17289021	PTFE-isolator SR 17-18-26 18CG
70	17961002	Collet body 17-18-26-220 / 1,0 10N30
70	17961602	Collet body 17-18-26-220 / 1,6 10N31
70	17962402	Collet body 17-18-26-220 / 2,4 10N32
71	17961011	Gas lens 17-18-26-220 / 1,0 45V24
71	17961611	Gas lens 17-18-26-220 / 1,6 45V25
71	17962411	Gas lens 17-18-26-220 / 2,4 45V26
72	17961021	Jumbo gas lens 17-18-26-220 / 1,0 45V0204
72	17961621	Jumbo gas lens 17-18-26-220 / 1,6 45V116
72	17962421	Jumbo gas lens 17-18-26-220 / 2,4 45V64
73	17961031	Gas lens "Mini" SR 17-18-26 / 1,0 conversion kit
73	17961631	Gas lens "Mini" SR 17-18-26 / 1,6 conversion kit
73	17962431	Gas lens "Mini" SR 17-18-26 / 2,4 conversion kit
74	18961003	Collet body "Mini" SR 17-18-26 1,0 conversion kit
74	18961603	Collet body "Mini" SR 17-18-26 1,6 conversion kit
74	18962403	Collet body "Mini" SR 17-18-26 2,4 conversion kit
74	18963203	Collet body "Mini" SR 17-18-26 / 1,0 - 3,2 17CB20 conversion kit

Welding-torch TIG gas-cooled**140A at 100% duty cycle (DC) - 125A at 100% duty cycle (AC)****Art.-No.**

Brazen collets L-50mm
suitable equipment line (A) standard collet body
suitable equipment line (B) gas lens
suitable equipment line (D) gas lens jumbo

75	17105002	Collet L50mm SR 17-18-26 wp-18SC / 1,0	10N22
75	17165002	Collet L50mm SR 17-18-26 wp-18SC / 1,6	10N23
75	17245002	Collet L50mm SR 17-18-26 wp-18SC / 2,4	10N24

Copper-collets L-29mm
suitable equipment line (E) gas lens mini
suitable equipment line (F) standard collet body mini

77	17103002	Collet L29mm SR 17-18-26 "Mini" 1,0	10N22S
77	17163002	Collet L29mm SR 17-18-26 "Mini" 1,6	10N23S
77	17243002	Collet L29mm SR 17-18-26 "Mini" 1,6	10N23S

78	17089021	PTFE-Gas-lens insulator 17-18-26-220	54N01
79	17089031	PTFE-Gas-lens insulator Jumbo 17-18-26-220	54N63

Ceramic gas nozzles in different lengths
suitable equipment line (A) standard collet body

80	17930401	Ceramic gas nozzle L47mm 17-18-26-220 / Gr.4	10N50 (pu=10pieces)
80	17930501	Ceramic gas nozzle L47mm 17-18-26-220 / Gr.5	10N49 (pu=10pieces)
80	17930601	Ceramic gas nozzle L47mm 17-18-26-220 / Gr.6	10N48 (pu=10pieces)
80	17930701	Ceramic gas nozzle L47mm 17-18-26-220 / Gr.7	10N47 (pu=10pieces)
80	17930801	Ceramic gas nozzle L47mm 17-18-26-220 / Gr.8	10N46 (pu=10pieces)
80	17930101	Ceramic gas nozzle L47mm 17-18-26-220 / Gr.10	10N45 (pu=10pieces)
80	17930121	Ceramic gas nozzle L47mm 17-18-26-220 / Gr.12	10N44 (pu=10pieces)

N.i.	17930404	Ceramic gas nozzle L76mm 17-18-26-220 / Gr.4	10N50L (pu=10pieces)
N.i.	17930504	Ceramic gas nozzle L76mm 17-18-26-220 / Gr.5	10N49L (pu=10pieces)
N.i.	17930604	Ceramic gas nozzle L76mm 17-18-26-220 / Gr.6	10N48L (pu=10pieces)
N.i.	17930704	Ceramic gas nozzle L76mm 17-18-26-220 / Gr.7	10N47L (pu=10pieces)

Ceramic gas nozzles in different lengths
suitable equipment line (B) gas lens

90	22093041	Gas nozzle for gas lens L42mm / Gr.4	54N18 (pu=10pieces)
90	22093051	Gas nozzle for gas lens L42mm / Gr.5	54N17 (pu=10pieces)
90	22093061	Gas nozzle for gas lens L42mm / Gr.6	54N16 (pu=10pieces)
90	22093071	Gas nozzle for gas lens L42mm / Gr.7	54N15 (pu=10pieces)
90	22093081	Gas nozzle for gas lens L42mm / Gr.8	54N14 (pu=10pieces)
90	22093111	Gas nozzle for gas lens L42mm / Gr.11	54N19-11 (pu=10pieces)
90	22093121	Gas nozzle for gas lens L42mm / Gr.12	54N19 (pu=10pieces)

N.i.	22093054	Gas nozzle for gas lens L76mm / Gr.5	54N17L (pu=10pieces)
N.i.	22093064	Gas nozzle for gas lens L76mm / Gr.6	54N16L (pu=10pieces)
N.i.	22093074	Gas nozzle for gas lens L76mm / Gr.7	54N15L (pu=10pieces)
N.i.	22093084	Gas nozzle for gas lens L76mm / Gr.8	54N14L (pu=10pieces)

Ceramic gas nozzles jumbo in different lengths
suitable equipment line (D) gas lens jumbo

95	22093066	Jumbo gas nozzle L48mm / Gr.6	57N75 (pu=10pieces)
95	22093086	Jumbo gas nozzle L48mm / Gr.8	57N74 (pu=10pieces)

Welding-torch TIG gas-cooled**140A at 100% duty cycle (DC) - 125A at 100% duty cycle (AC)**

Art.-No.		
95	22093106	Jumbo gas nozzle L48mm / Gr.10 53N88 (pu=10pieces)
95	22093126	Jumbo gas nozzle L48mm / Gr.12 53N87 (pu=10pieces)
N.i.	22093067	Jumbo gas nozzle L73mm / Gr.6 57N75L (pu=10pieces)
N.i.	22093087	Jumbo gas nozzle L73mm / Gr.8 57N74L (pu=10pieces)
N.i.	22093107	Jumbo gas nozzle L73mm / Gr.10 53N88L (pu=10pieces)
N.i.	22093127	Jumbo gas nozzle L73mm / Gr.12 53N87L (pu=10pieces)

**Ceramic gas nozzles L-20mm
suitable equipment line (E) gas lens mini**

96	17930502	Ceramic gas nozzle L20mm SR 17-18-26 / Gr.5 fits gas lens "Mini" 53N59MS (pu=10pieces)
96	17930602	Ceramic gas nozzle L20mm SR 17-18-26 / Gr.6 fits gas lens "Mini" 53N60MS (pu=10pieces)
96	17930702	Ceramic gas nozzle L20mm SR 17-18-26 / Gr.7 fits gas lens "Mini" 53N61MS (pu=10pieces)

**Ceramic gas nozzles
suitable equipment line (F) collet body standard mini**

97	20930401	Ceramic gas nozzle L30mm / Gr. 4 13N08 (pu=10pieces)
97	20930501	Ceramic gas nozzle L30mm / Gr. 5 13N09 (pu=10pieces)
97	20930601	Ceramic gas nozzle L30mm / Gr. 6 13N10 (pu=10pieces)
97	20930701	Ceramic gas nozzle L30mm / Gr. 7 13N11 (pu=10pieces)
97	20930801	Ceramic gas nozzle L30mm / Gr. 8 13N12 (pu=10pieces)
97	20930101	Ceramic gas nozzle L30mm / Gr.10 13N13 (pu=10pieces)
N.i.	20930304	Ceramic gas nozzle L48mm / Gr. 3 796F70 (pu=10pieces)
N.i.	20930404	Ceramic gas nozzle L48mm / Gr. 4 796F71 (pu=10pieces)
N.i.	20930504	Ceramic gas nozzle L48mm / Gr. 5 796F72 (pu=10pieces)
o.A	20930604	Ceramic gas nozzle L48mm / Gr. 6 796F73 (pu=10pieces)
N.i.	20930306	Ceramic gas nozzle L63mm / Gr. 3 796F74 (pu=10pieces)
N.i.	20930406	Ceramic gas nozzle L63mm / Gr. 4 796F75 (pu=10pieces)
N.i.	20930506	Ceramic gas nozzle L63mm / Gr. 5 796F76 (pu=10pieces)
N.i.	20930606	Ceramic gas nozzle L63mm / Gr. 6 796F77 (pu=10pieces)
N.i.	20930408	Ceramic gas nozzle L89mm / Gr. 4 796F79 (pu=10pieces)

Top quality tungsten electrodes in 9 different qualities, see appendix A.

Torch SR 26-TW gas-cooled



Holch Schweißbrenner GmbH
Bühlstraße 14
D-57080 Siegen

Phone: +49(0)271 387860-11
Telefax: +49(0)271 387860-29
E-Mail: info@holch-siegen.de
Web: www.holch-siegen.de



SR 26-TW gas-cooled

240 Ampere at 100% duty cycle (DC) - 200 Ampere at 100% duty cycle (AC)

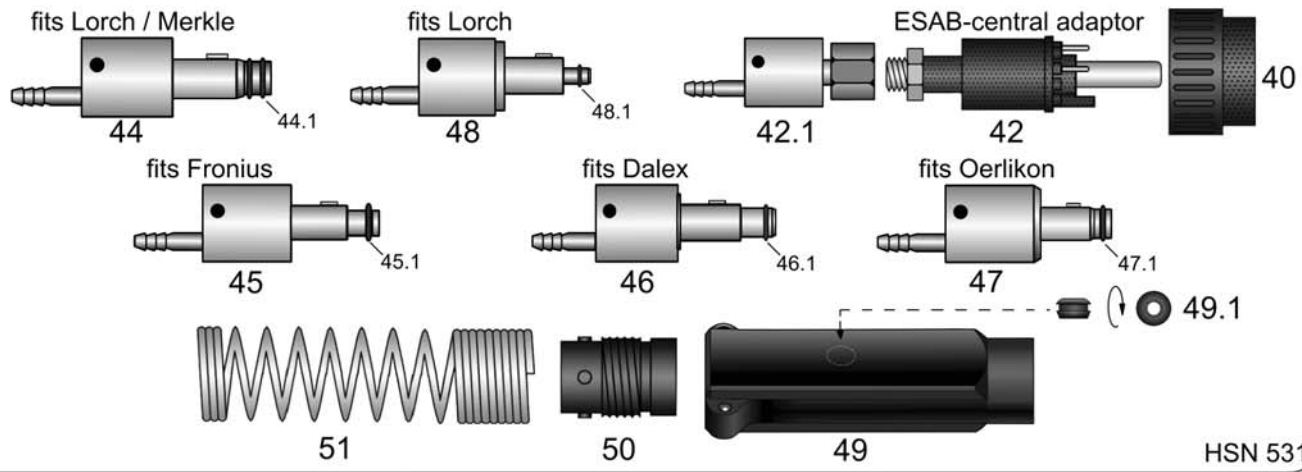
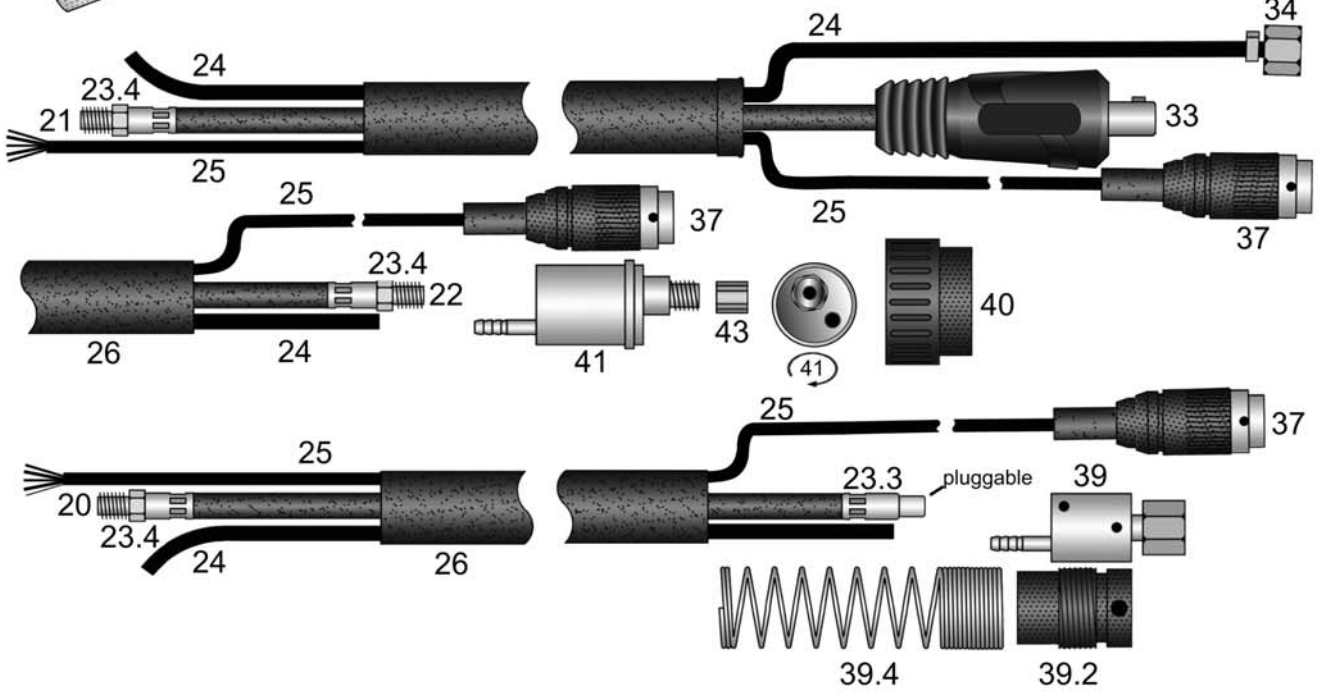
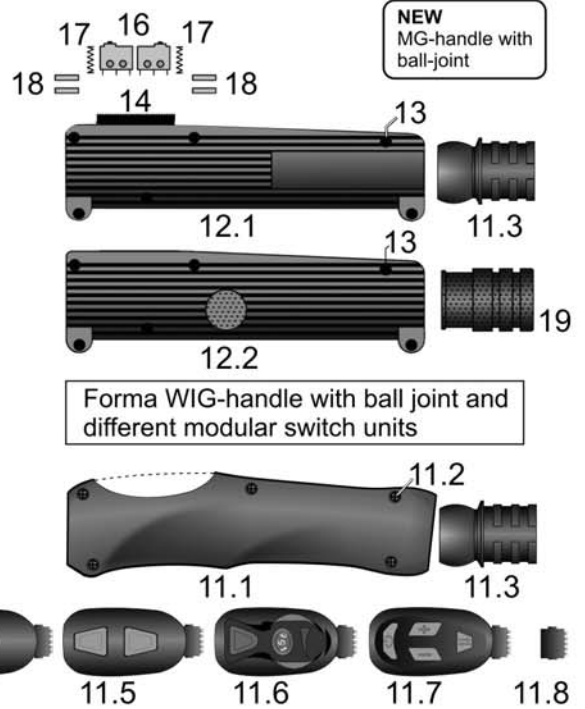
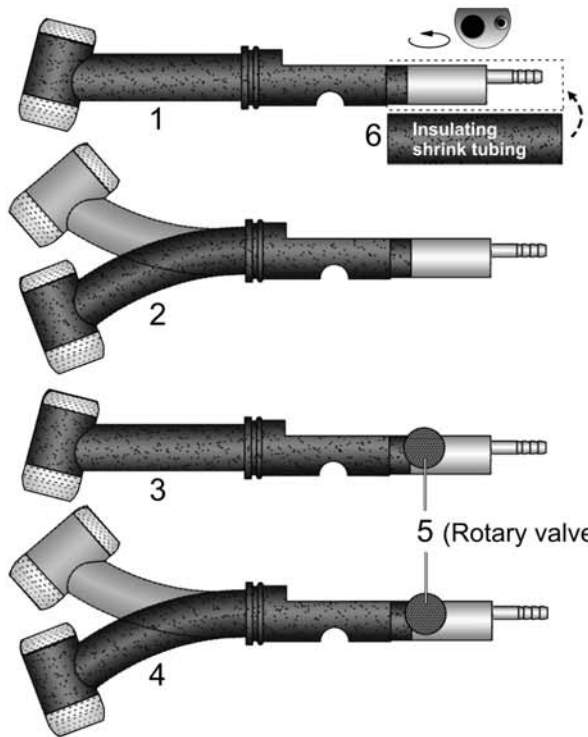

SR 26 - TW gas-cooled spare parts



Equipment: **A** standard
B gas lens
D gas lens jumbo
E gas lens mini
F standard mini

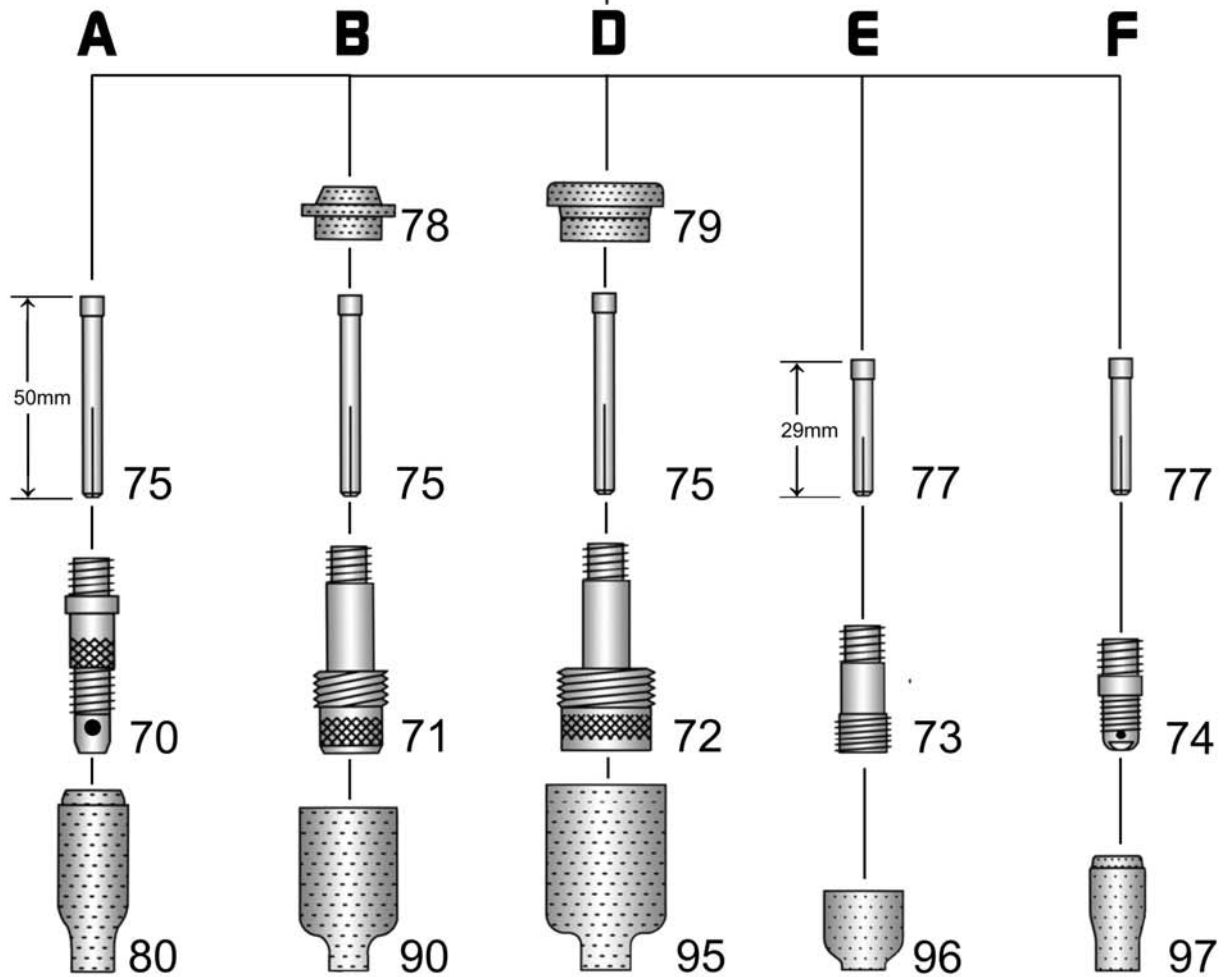
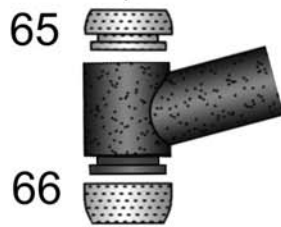
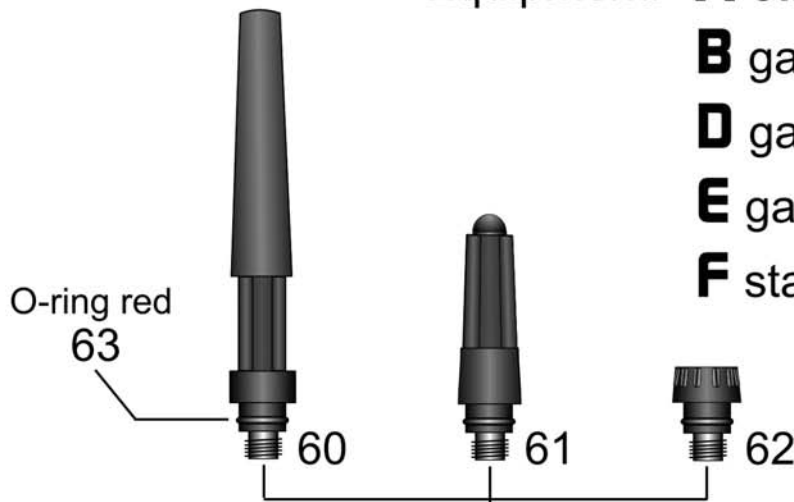

HSN 113

Welding-torch TIG gas-cooled**240A at 100% duty cycle (DC) - 200A at 100% duty cycle (AC)****Art.-No.**

Torches with first meter leather hose. Prices without leather on request. Machine side separate connections.

Torches and cable assemblies can be produced in excess lengths. Please find the different options and surcharges in the attachment "Custom made products" appendix C. We produce torches for more than 40 different brands of machines with different connection systems.

26600401 Torch SR 26-TW / 4m 35mm²26600801 Torch SR 26-TW / 8m 35mm²26700401 FLEX-torch SR 26F-TW / 4m 35mm² neck flexible26700801 FLEX-torch SR 26F-TW / 8m 35mm² neck flexible26800401 Valve torch SR 26V-TW / 4m 35mm²26800801 Valve torch SR 26V-TW / 8m 35mm²26900401 FLEX-Valve torch SR 26FV-TW / 4m 35mm² neck flexible26900801 FLEX-Valve torch SR 26FV-TW / 8m 35mm² neck flexible

TIG-spare cable assemblies in different qualities, machine side with separate connections and Tichel plug, or, if ordered so, with the following connection systems:

wig92401 TIG-spare cable assembly gas-cooled 4m - please state desired design!

wig92801 TIG-spare cable assembly gas-cooled 8m - please state desired design!

The following surcharges for machine side connections are only to find prices quickly. Please use our catalogue "TIG machine side connections" to find a "T"number which identifies a machine side connection system completely.

29000101 Surcharge: machine side with EURO central adapter

29002005 Surcharge: machine side power/gas plug fits Lorch/Merkle with 2 O-rings

29002004 Surcharge: machine side power/gas plug fits Fronius with 1 O-ring

29002006 Surcharge: machine side power/gas plug fits Dalex with 1 O-ring

29002107 Surcharge: machine side power/gas plug fits Oerlikon with 1 O-ring

29002002 Surcharge: machine side power/gas plug fits Lorch SK35 + gas-nipple

29000112 Surcharge: machine side fits ESAB central adapter, 4 pins installed at position 3,4,5,6

poti2901 Surcharge: 1 button with additional potentiometer

ud290001 Surcharge: 4 switches > up / down

Please note that there might be additional charges for special control line plugs. See appendix D.

1 26691001 Torch body SR 26-TW

2 26791001 Torch body SR 26F-TW neck flexible (FLEX)

3 26891001 Torch body with valve SR 26V-TW

4 26991001 Torch body with valve SR 26FV-TW neck flexible (FLEX)

5 90789001 Rotary valve TW complete with O-rings

N.i. 17389013 O-Ring ID3-W1,5mm fits rotary valve TW inside (material hepthon 951)

N.i. 17389012 O-Ring ID4,6-W2mm fits rotary valve TW outside (material hepthon 951)

6 18050002 Ignition insulating hose L75mm / ID39mm down to ID13mm

11.1 91914601 Forma TIG handle with screws, ball joint, without modular switch unit

11.2 91914602 Forma screw for handle

11.3 91914603 Forma hose bracket with ball joint ID21,5mm (also fits MG-handle)

11.4 91914611 Forma modular switch unit: 1 button with connecting adapter

11.5 91914621 Forma modular switch unit: 2 buttons with connecting adapter

Welding-torch TIG gas-cooled**240A at 100% duty cycle (DC) - 200A at 100% duty cycle (AC)**

Art.-No.		
11.6	91914631	Forma modular switch unit: 1 button + potentiometer (10k) with connecting adapter
11.7	91914641	Forma modular switch unit: 2 buttons + up/down (4 switches) with connecting adapter
11.8	91914651	Forma connecting adapter fits control line to modular switch unit
N.i.	91914661	Forma switch module safety nipple
12.1	91914061	MG-handle with ball joint, push-button, 2 return springs, 2 microswitches and 4 cylindrical pins
12.2	91914033	MG-handle fits TW valve torch
13	91914421	MG-tapping screw
14	91915002	MG-push button
16	91914121	MG-microswitch
17	91914221	MG-return spring
18	91914321	MG-cylindrical pin
19	91915001	MG-hose bracket without ball joint ID19,5mm
20	26942403	Power cable 35mm ² 26/220-TW / 4m fits power/gas plugs + power gas junction (pgj)
20	26942803	Power cable 35mm ² 26/220-TW / 8m fits power/gas plugs + power gas junction (pgj)
21	26942402	Power cable 35mm ² 26/220-TW / 4m with SK25 or SK35 <--- please state!
21	26942802	Power cable 35mm ² 26/220-TW / 8m with SK25 or SK35 <--- please state!
22	26942404	Power cable 35mm ² 26/220-TW / 4m EURO fits central adapter (OT-M10x1)
22	26942804	Power cable 35mm ² 26/220-TW / 8m EURO fits central adapter (OT-M10x1)
23.3	22089057	TIG-Power cable connector plugable ID8,2mm fits 35mm ²
23.4	22089054	TIG-Power cable connector OT-M10x1 ID8,2mm fits 35mm ²
Reel goods:		
Prices are per meter and only applicable for purchasing of complete rolls		
24	41500001	Meter ST 70 PVC hose ID4,0-W1,5mm black for gas (100m)
N.i.	91902701	Meter control line 3x0,34mm ² shielded black (100m)
N.i.	91902711	Meter control line 3x0,5mm ² red (100m)
25	91902721	Meter control line 5x0,25mm ² grey (100m)
26	22150002	Meter neoprene protective hose ID22mm black (40m)
N.i.	91915004	Leather protective hose ID22mm / 1 meter long
N.i.	91915007	Leather protective hose ID22mm / 1 meter long with ball joint and hose connector
N.i.	91915003	Hose connector leather protective hose / protection hose ID19,5mm
33	91918201	Powercable-plug SK-25 bayonet connection AD8mm
33	91918301	Powercable-plug SK-35 bayonet connection AD13mm
34	91901501	Coupling nut IT-G1/4"
N.i.	91901211	Hose connector 4mm fits coupling nut R1/4"
37	91904101	Plug 3-poles Tuchel with bayonet-catch
37	91904111	Plug 5-poles Tuchel with bayonet-catch
More control line plugs see appendix D		
39	91918521	TIG power gas junction (pgj) with connection: IT-G1/8"
39	91918522	TIG power gas junction (pgj) with connection: IT-G1/4"
39	91918523	TIG power gas junction (pgj) with connection: IT-G3/8"
N.i.	91918551	Attachment screw (plastic) M5x12mm for power gas junction (pgj)
N.i.	91918552	3 grommets for attachment screws M5x12mm power gas junction (pgj)
N.i.	91918542	Section of insulating-hose ID35-L80mm power gas junction (pgj)

Welding-torch TIG gas-cooled**240A at 100% duty cycle (DC) - 200A at 100% duty cycle (AC)**

Art.-No.		
39.2	91918541	TIG spring socket small power gas junction (pgj)
39.4	91918531	Cable support spring L125mm for power gas junction (pgj)
40	91900701	Terminal nut insulated fits EURO central adapter
41	91900122	TIG central adapter EURO (fits separate lines)
42	91900301	TIG central adapter identical ESAB, 4 contact pins at position 3,4,5,6
42.1	91918561	TIG power gas junction (pgj) fits ESAB central adapter
43	91900901	Coupling nut IT-M10x1 (rounded edges) fits EURO central adapter
44	9190411n	Power/gas plug fits Lorch / Merkle with 2 O-rings / power connection like pgj
44.1	81600001	O-ring ID8-W1,6mm fits Lorch/Merkle
45	91918326	Power/gas plug fits Fronius with 1 O-ring / power connection like pgj
45.1	62190001	O-ring ID6,2-W1,9mm fits Fronius
46	9190416e	Power/gas plug fits Dalex with 1 O-ring / power connection like pgj
46.1	63240001	O-ring ID6,3-W2,4mm fits Dalex
47	9190422n	Power/gas plug fits Oerlikon with 1 O-ring / power connection like pgj
47.1	60717801	O-ring ID6,07-W1,78mm fits Oerlikon
48	9190421n	Power/gas plug fits Lorch Sk35 + gas-nipple / power connection like pgj
48.1	91900801	O-ring ID4-W1mm fits gas-nipple EURO central adapter
N.i.	91900552	TIG cable support long (like MIG-MAG) with screws fits ESAB central adapter
N.i.	91900554	Attachment screw M4x8mm fits ESAB central adapter
49	91900556	TIG cable support short with screws (fits gas-cooled)
N.i.	91920702	Screw M3x11,5mm for Ratio/Industry/RAUCH handle and cable support
N.i.	91920703	M3 mounting socket for Ratio/Industry/RAUCH handle and cable support
o.A.	91900602	Screw M4x6mm for TIG cable support short
49.1	91901012	Reduction-eyellet (rubber) from ID10,5mm to ID5mm fits TIG cable support short
50	91912801	Spring-socket EURO central adapter
51	91912601	Cable support spring fits EURO / ESAB central adapter
60	17191311	Holch back cap long (USA version with red O-ring) SR 17-18-26 57Y02
61	17191322	Import back cap medium (USA version with red O-ring) SR 17-18-26 57Y03
62	17191301	Holch back cap short (USA version with red O-ring) SR 17-18-26 57Y04
63	17189001	O-ring red ID8-W2mm for back cap
65	17289001	PTFE-back-cap gasket ring SR 17-18-26 18-7
66	17289021	PTFE-isolator SR 17-18-26 18CG
70	17961002	Collet body 17-18-26-220 / 1,0 10N30
70	17961602	Collet body 17-18-26-220 / 1,6 10N31
70	17962402	Collet body 17-18-26-220 / 2,4 10N32
70	18963202	Collet body 17-18-26-220 / 3,2 10N28
71	17961011	Gas lens 17-18-26-220 / 1,0 45V24
71	17961611	Gas lens 17-18-26-220 / 1,6 45V25
71	17962411	Gas lens 17-18-26-220 / 2,4 45V26
71	18963211	Gas lens 17-18-26-220 / 3,2 45V27
72	17961021	Jumbo gas lens 17-18-26-220 / 1,0 45V0204
72	17961621	Jumbo gas lens 17-18-26-220 / 1,6 45V116
72	17962421	Jumbo gas lens 17-18-26-220 / 2,4 45V64
72	18963221	Jumbo gas lens 17-18-26-220 / 3,2 995795
73	17961031	Gas lens "Mini" SR 17-18-26 / 1,0 conversion kit

Welding-torch TIG gas-cooled**240A at 100% duty cycle (DC) - 200A at 100% duty cycle (AC)**

Art.-No.		
73	17961631	Gas lens "Mini" SR 17-18-26 / 1,6 conversion kit
73	17962431	Gas lens "Mini" SR 17-18-26 / 2,4 conversion kit
73	18963231	Gas lens "Mini" SR 17-18-26 / 3,2 conversion kit
Brazen collets L-50mm		
suitable equipment line (A) standard collet body		
suitable equipment line (B) gas lens		
suitable equipment line (D) gas lens jumbo		
74	18961003	Collet body "Mini" SR 17-18-26 1,0 conversion kit
74	18961603	Collet body "Mini" SR 17-18-26 1,6 conversion kit
74	18962403	Collet body "Mini" SR 17-18-26 2,4 conversion kit
74	18963203	Collet body "Mini" SR 17-18-26 / 1,0 - 3,2 17CB20 conversion kit
Copper-collets L-29mm		
suitable equipment line (E) gas lens mini		
suitable equipment line (F) standard collet body mini		
75	17105002	Collet L50mm SR 17-18-26 wp-18SC / 1,0 10N22
75	17165002	Collet L50mm SR 17-18-26 wp-18SC / 1,6 10N23
75	17245002	Collet L50mm SR 17-18-26 wp-18SC / 2,4 10N24
75	18325002	Collet L50mm SR 17-18-26 wp-18SC / 3,2 10N25
Ceramic gas nozzles in different lengths		
suitable equipment line (A) standard collet body		
77	17103002	Collet L29mm SR 17-18-26 "Mini" 1,0 10N22S
77	17163002	Collet L29mm SR 17-18-26 "Mini" 1,6 10N23S
77	17243002	Collet L29mm SR 17-18-26 "Mini" 1,6 10N23S
77	18323002	Collet L29mm SR 17-18-26 "Mini" 3,2 10N25S
78	17089021	PTFE-Gas-lens insulator 17-18-26-220 54N01
79	17089031	PTFE-Gas-lens insulator Jumbo 17-18-26-220 54N63
Ceramic gas nozzles in different lengths		
suitable equipment line (A) standard collet body		
80	17930401	Ceramic gas nozzle L47mm 17-18-26-220 / Gr.4 10N50 (pu=10pieces)
80	17930501	Ceramic gas nozzle L47mm 17-18-26-220 / Gr.5 10N49 (pu=10pieces)
80	17930601	Ceramic gas nozzle L47mm 17-18-26-220 / Gr.6 10N48 (pu=10pieces)
80	17930701	Ceramic gas nozzle L47mm 17-18-26-220 / Gr.7 10N47 (pu=10pieces)
80	17930801	Ceramic gas nozzle L47mm 17-18-26-220 / Gr.8 10N46 (pu=10pieces)
80	17930101	Ceramic gas nozzle L47mm 17-18-26-220 / Gr.10 10N45 (pu=10pieces)
80	17930121	Ceramic gas nozzle L47mm 17-18-26-220 / Gr.12 10N44 (pu=10pieces)
N.i.	17930404	Ceramic gas nozzle L76mm 17-18-26-220 / Gr.4 10N50L (pu=10pieces)
N.i.	17930504	Ceramic gas nozzle L76mm 17-18-26-220 / Gr.5 10N49L (pu=10pieces)
N.i.	17930604	Ceramic gas nozzle L76mm 17-18-26-220 / Gr.6 10N48L (pu=10pieces)
N.i.	17930704	Ceramic gas nozzle L76mm 17-18-26-220 / Gr.7 10N47L (pu=10pieces)
Ceramic gas nozzles in different lengths		
suitable equipment line (B) gas lens		
90	22093041	Gas nozzle for gas lens L42mm / Gr.4 54N18 (pu=10pieces)
90	22093051	Gas nozzle for gas lens L42mm / Gr.5 54N17 (pu=10pieces)
90	22093061	Gas nozzle for gas lens L42mm / Gr.6 54N16 (pu=10pieces)
90	22093071	Gas nozzle for gas lens L42mm / Gr.7 54N15 (pu=10pieces)
90	22093081	Gas nozzle for gas lens L42mm / Gr.8 54N14 (pu=10pieces)
90	22093111	Gas nozzle for gas lens L42mm / Gr.11 54N19-11 (pu=10pieces)
90	22093121	Gas nozzle for gas lens L42mm / Gr.12 54N19 (pu=10pieces)

Welding-torch TIG gas-cooled**240A at 100% duty cycle (DC) - 200A at 100% duty cycle (AC)****Art.-No.**

N.i.	22093054	Gas nozzle for gas lens L76mm / Gr.5	54N17L	(pu=10pieces)
N.i.	22093064	Gas nozzle for gas lens L76mm / Gr.6	54N16L	(pu=10pieces)
N.i.	22093074	Gas nozzle for gas lens L76mm / Gr.7	54N15L	(pu=10pieces)
N.i.	22093084	Gas nozzle for gas lens L76mm / Gr.8	54N14L	(pu=10pieces)

**Ceramic gas nozzles jumbo in different lengths
suitable equipment line (D) gas lens jumbo**

95	22093066	Jumbo gas nozzle L48mm / Gr.6	57N75	(pu=10pieces)
95	22093086	Jumbo gas nozzle L48mm / Gr.8	57N74	(pu=10pieces)
95	22093106	Jumbo gas nozzle L48mm / Gr.10	53N88	(pu=10pieces)
95	22093126	Jumbo gas nozzle L48mm / Gr.12	53N87	(pu=10pieces)

N.i.	22093067	Jumbo gas nozzle L73mm / Gr.6	57N75L	(pu=10pieces)
N.i.	22093087	Jumbo gas nozzle L73mm / Gr.8	57N74L	(pu=10pieces)
N.i.	22093107	Jumbo gas nozzle L73mm / Gr.10	53N88L	(pu=10pieces)
N.i.	22093127	Jumbo gas nozzle L73mm / Gr.12	53N87L	(pu=10pieces)

**Ceramic gas nozzles L-20mm
suitable equipment line (E) gas lens mini**

96	17930502	Ceramic gas nozzle L20mm SR 17-18-26 / Gr.5 fits gas lens "Mini"	53N59MS	(pu=10pieces)
96	17930602	Ceramic gas nozzle L20mm SR 17-18-26 / Gr.6 fits gas lens "Mini"	53N60MS	(pu=10pieces)
96	17930702	Ceramic gas nozzle L20mm SR 17-18-26 / Gr.7 fits gas lens "Mini"	53N61MS	(pu=10pieces)

**Ceramic gas nozzles
suitable equipment line (F) collet body standard mini**

97	20930401	Ceramic gas nozzle L30mm / Gr. 4	13N08	(pu=10pieces)
97	20930501	Ceramic gas nozzle L30mm / Gr. 5	13N09	(pu=10pieces)
97	20930601	Ceramic gas nozzle L30mm / Gr. 6	13N10	(pu=10pieces)
97	20930701	Ceramic gas nozzle L30mm / Gr. 7	13N11	(pu=10pieces)
97	20930801	Ceramic gas nozzle L30mm / Gr. 8	13N12	(pu=10pieces)
97	20930101	Ceramic gas nozzle L30mm / Gr.10	13N13	(pu=10pieces)

N.i.	20930304	Ceramic gas nozzle L48mm / Gr. 3	796F70	(pu=10pieces)
N.i.	20930404	Ceramic gas nozzle L48mm / Gr. 4	796F71	(pu=10pieces)
N.i.	20930504	Ceramic gas nozzle L48mm / Gr. 5	796F72	(pu=10pieces)
o.A	20930604	Ceramic gas nozzle L48mm / Gr. 6	796F73	(pu=10pieces)

N.i.	20930306	Ceramic gas nozzle L63mm / Gr. 3	796F74	(pu=10pieces)
N.i.	20930406	Ceramic gas nozzle L63mm / Gr. 4	796F75	(pu=10pieces)
N.i.	20930506	Ceramic gas nozzle L63mm / Gr. 5	796F76	(pu=10pieces)
N.i.	20930606	Ceramic gas nozzle L63mm / Gr. 6	796F77	(pu=10pieces)

N.i.	20930408	Ceramic gas nozzle L89mm / Gr. 4	796F79	(pu=10pieces)
------	----------	----------------------------------	--------	---------------

Top quality tungsten electrodes in 9 different qualities, see appendix A.

Torch ABL 220-TW gas-cooled



Holch Schweißbrenner GmbH
Bühlstraße 14
D-57080 Siegen

Phone: +49(0)271 387860-11
Telefax: +49(0)271 387860-29
E-Mail: info@holch-siegen.de
Web: www.holch-siegen.de



ABL 220-TW gas-cooled

240 Ampere at 100% duty cycle (DC) - 200 Ampere at 100% duty cycle (AC)

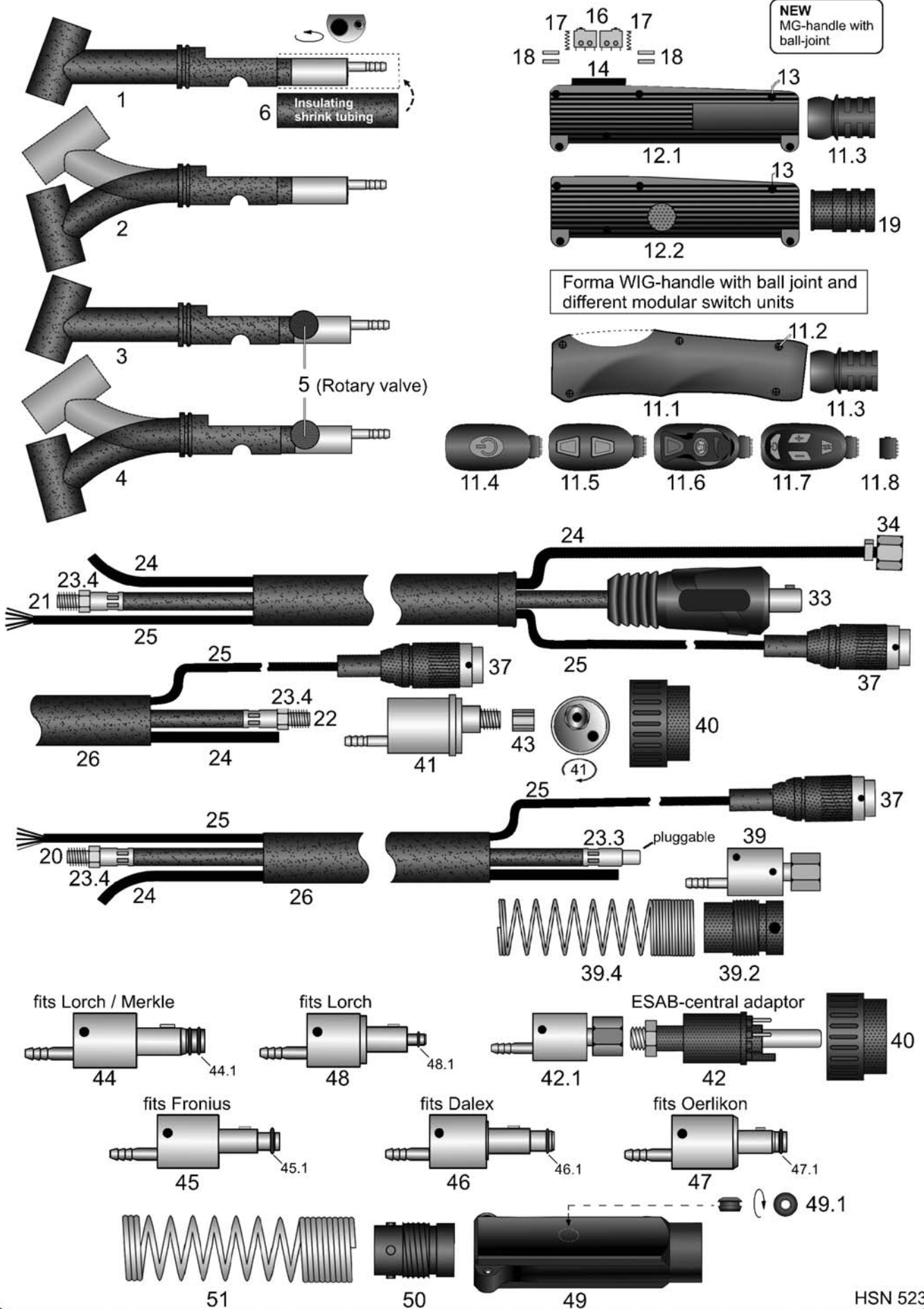

HSN 523

ABL 220 - TW gas-cooled spare parts



Equipment: **A** standard
B gas lens
D gas lens jumbo
G standard retro 220

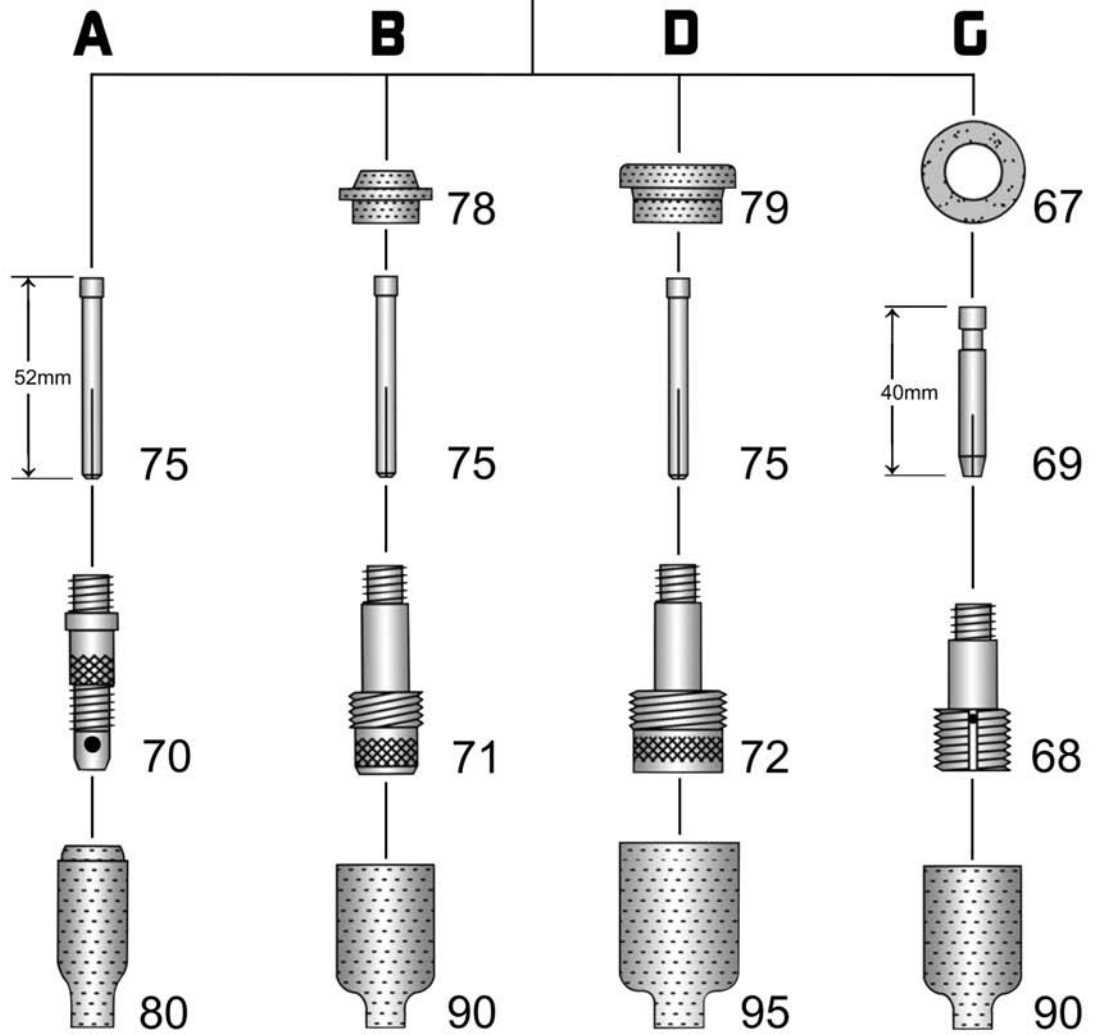
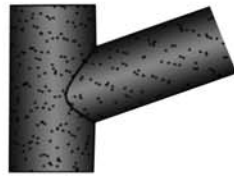
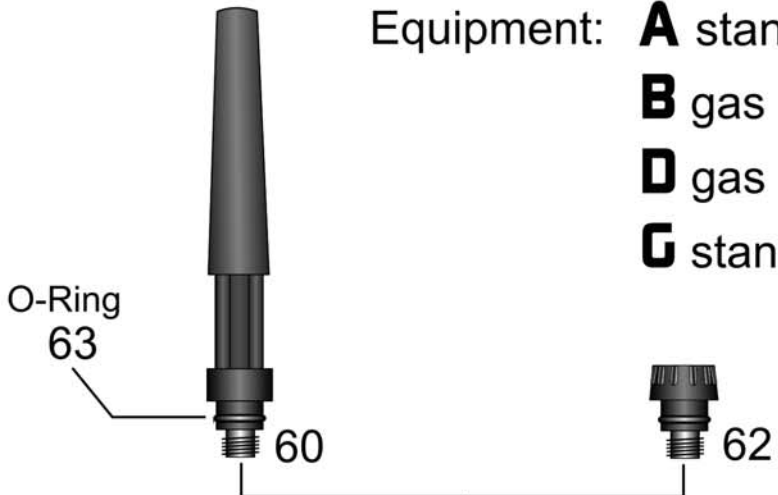

HSN 105

Welding-torch TIG gas-cooled

240A at 100% duty cycle (DC) - 200A at 100% duty cycle (AC)

Art.-No.

Torches with first meter leather hose. Prices without leather on request. Machine side separate connections.

Torches and cable assemblies can be produced in excess lengths. Please find the different options and surcharges in the attachment "Custom made products" appendix C. We produce torches for more than 40 different brands of machines with differnt connection systems.

22060401 Torch ABL 220-TW / 4m 35mm²

22060801 Torch ABL 220-TW / 8m 35mm²

22070401 FLEX-torch ABL 220F-TW / 4m 35mm² neck flexible

22070801 FLEX-torch ABL 220F-TW / 8m 35mm² neck flexible

22080401 Valve torch ABL 220V-TW / 4m 35mm²

22080801 Valve torch ABL 220V-TW / 8m 35mm²

22090401 FLEX-Valve torch ABL 220FV-TW / 4m 35mm² neck flexible

22090801 FLEX-Valve torch ABL 220FV-TW / 8m 35mm² neck flexible

TIG-spare cable assemblies in different qualities, machine side with separate connections and Tichel plug, or, if ordered so, with the following connection systems:

wig92401 TIG-spare cable assembly gas-cooled 4m - please state desired design!

wig92801 TIG-spare cable assembly gas-cooled 8m - please state desired design!

The following surcharges for machine side connections are only to find prices quickly. Please use our catalogue "TIG machine side connections" to find a "T"number which identifies a machine side connection system completely.

29000101 Surcharge: machine side with EURO central adapter

29002005 Surcharge: machine side power/gas plug fits Lorch/Merkle with 2 O-rings

29002004 Surcharge: machine side power/gas plug fits Fronius with 1 O-ring

29002006 Surcharge: machine side power/gas plug fits Dalex with 1 O-ring

29002107 Surcharge: machine side power/gas plug fits Oerlikon with 1 O-ring

29002002 Surcharge: machine side power/gas plug fits Lorch SK35 + gas-nipple

29000112 Surcharge: machine side fits ESAB central adapter, 4 pins installed at position 3,4,5,6

poti2901 Surcharge: 1 button with additional potentiometer

ud290001 Surcharge: 4 switches > up / down

Please note that there might be additional charges for special control line plugs. See appendix D.

1 22069101 Torch body ABL 220-TW

2 22079101 Torch body ABL 220F-TW neck flexible (FLEX)

3 22089101 Torch body with valve ABL 220V-TW

4 22099101 Torch body with valve ABL 220FV-TW neck flexible (FLEX)

5 90789001 Rotary valve TW complete with O-rings

N.i. 17389013 O-Ring ID3-W1,5mm fits rotary valve TW inside (material hepthon 951)

N.i. 17389012 O-Ring ID4,6-W2mm fits rotary valve TW outside (material hepthon 951)

6 18050002 Ignition insulating hose L75mm / ID39mm down to ID13mm

11.1 91914601 Forma TIG handle with screws, ball joint, without modular switch unit

11.2 91914602 Forma screw for handle

11.3 91914603 Forma hose bracket with ball joint ID21,5mm (also fits MG-handle)

11.4 91914611 Forma modular switch unit: 1 button with connecting adapter

11.5 91914621 Forma modular switch unit: 2 buttons with connecting adapter

Welding-torch TIG gas-cooled**240A at 100% duty cycle (DC) - 200A at 100% duty cycle (AC)**

Art.-No.		
11.6	91914631	Forma modular switch unit: 1 button + potentiometer (10k) with connecting adapter
11.7	91914641	Forma modular switch unit: 2 buttons + up/down (4 switches) with connecting adapter
11.8	91914651	Forma connecting adapter fits control line to modular switch unit
N.i.	91914661	Forma switch module safety nipple
12.1	91914061	MG-handle with ball joint, push-button, 2 return springs, 2 microswitches and 4 cylindrical pins
12.2	91914033	MG-handle fits TW valve torch
13	91914421	MG-tapping screw
14	91915002	MG-push button
16	91914121	MG-microswitch
17	91914221	MG-return spring
18	91914321	MG-cylindrical pin
19	91915001	MG-hose bracket without ball joint ID19,5mm
20	26942403	Power cable 35mm ² 26/220-TW / 4m fits power/gas plugs + power gas junction (pgj)
20	26942803	Power cable 35mm ² 26/220-TW / 8m fits power/gas plugs + power gas junction (pgj)
21	26942402	Power cable 35mm ² 26/220-TW / 4m with SK25 or SK35 <--- please state!
21	26942802	Power cable 35mm ² 26/220-TW / 8m with SK25 or SK35 <--- please state!
22	26942404	Power cable 35mm ² 26/220-TW / 4m EURO fits central adapter (OT-M10x1)
22	26942804	Power cable 35mm ² 26/220-TW / 8m EURO fits central adapter (OT-M10x1)
23.3	22089057	TIG-Power cable connector plugable ID8,2mm fits 35mm ²
23.4	22089054	TIG-Power cable connector OT-M10x1 ID8,2mm fits 35mm ²
Reel goods:		
Prices are per meter and only applicable for purchasing of complete rolls		
24	41500001	Meter ST 70 PVC hose ID4,0-W1,5mm black for gas (100m)
N.i.	91902701	Meter control line 3x0,34mm ² shielded black (100m)
N.i.	91902711	Meter control line 3x0,5mm ² red (100m)
25	91902721	Meter control line 5x0,25mm ² grey (100m)
26	22150002	Meter neoprene protective hose ID22mm black (40m)
N.i.	91915004	Leather protective hose ID22mm / 1 meter long
N.i.	91915007	Leather protective hose ID22mm / 1 meter long with ball joint and hose connector
N.i.	91915003	Hose connector leather protective hose / protection hose ID19,5mm
33	91918201	Powercable-plug SK-25 bayonet connection AD8mm
33	91918301	Powercable-plug SK-35 bayonet connection AD13mm
34	91901501	Coupling nut IT-G1/4"
N.i.	91901211	Hose connector 4mm fits coupling nut R1/4"
37	91904101	Plug 3-poles Tuchel with bayonet-catch
37	91904111	Plug 5-poles Tuchel with bayonet-catch
More control line plugs see appendix D		
39	91918521	TIG power gas junction (pgj) with connection: IT-G1/8"
39	91918522	TIG power gas junction (pgj) with connection: IT-G1/4"
39	91918523	TIG power gas junction (pgj) with connection: IT-G3/8"
N.i.	91918551	Attachment screw (plastic) M5x12mm for power gas junction (pgj)
N.i.	91918552	3 grommets for attachment screws M5x12mm power gas junction (pgj)

Welding-torch TIG gas-cooled**240A at 100% duty cycle (DC) - 200A at 100% duty cycle (AC)**

Art.-No.		
N.i.	91918542	Section of insulating-hose ID35-L80mm power gas junction (pgj)
39.2	91918541	TIG spring socket small power gas junction (pgj)
39.4	91918531	Cable support spring L125mm for power gas junction (pgj)
40	91900701	Terminal nut insulated fits EURO central adapter
41	91900122	TIG central adapter EURO (fits separate lines)
42	91900301	TIG central adapter identical ESAB, 4 contact pins at position 3,4,5,6
42.1	91918561	TIG power gas junction (pgj) fits ESAB central adapter
43	91900901	Coupling nut IT-M10x1 (rounded edges) fits EURO central adapter
44	9190411n	Power/gas plug fits Lorch / Merkle with 2 O-rings / power connection like pgj
44.1	81600001	O-ring ID8-W1,6mm fits Lorch/Merkle
45	91918326	Power/gas plug fits Fronius with 1 O-ring / power connection like pgj
45.1	62190001	O-ring ID6,2-W1,9mm fits Fronius
46	9190416e	Power/gas plug fits Dalex with 1 O-ring / power connection like pgj
46.1	63240001	O-ring ID6,3-W2,4mm fits Dalex
47	9190422n	Power/gas plug fits Oerlikon with 1 O-ring / power connection like pgj
47.1	60717801	O-ring ID6,07-W1,78mm fits Oerlikon
48	9190421n	Power/gas plug fits Lorch Sk35 + gas-nipple / power connection like pgj
48.1	91900801	O-ring ID4-W1mm fits gas-nipple EURO central adapter
N.i.	91900552	TIG cable support long (like MIG-MAG) with screws fits ESAB central adapter
N.i.	91900554	Attachment screw M4x8mm fits ESAB central adapter
49	91900556	TIG cable support short with screws (fits gas-cooled)
N.i.	91920702	Screw M3x11,5mm for Ratio/Industry/RAUCH handle and cable support
N.i.	91920703	M3 mounting socket for Ratio/Industry/RAUCH handle and cable support
o.A.	91900602	Screw M4x6mm for TIG cable support short
49.1	91901012	Reduction-eyelet (rubber) from ID10,5mm to ID5mm fits TIG cable support short
50	91912801	Spring-socket EURO central adapter
51	91912601	Cable support spring fits EURO / ESAB central adapter
60	17091311	Holch back cap long (german version with black O-ring) AS17-AS18-ABL220 57Y02-D
62	17091301	Holch back cap short (german version with black O-ring) AS17-AS18-ABL220 57Y04-D
63	17089011	O-ring black ID9-W2,5mm for back cap
67	22089071	Ceramic gas nozzle gasket ABL 220
68	22096001	Copper collet body ABL 220 up to 3,2mm
Brazen collets L-40mm suitable equipment line (G) standard Retro 220		
69	22010402	Collet L40mm ABL 220 / 1,0
69	22016402	Collet L40mm ABL 220 / 1,6
69	22024402	Collet L40mm ABL 220 / 2,4
69	22032402	Collet L40mm ABL 220 / 3,2
70	17961002	Collet body 17-18-26-220 / 1,0 10N30
70	17961602	Collet body 17-18-26-220 / 1,6 10N31
70	17962402	Collet body 17-18-26-220 / 2,4 10N32
70	18963202	Collet body 17-18-26-220 / 3,2 10N28
71	17961011	Gas lens 17-18-26-220 / 1,0 45V24

Welding-torch TIG gas-cooled

240A at 100% duty cycle (DC) - 200A at 100% duty cycle (AC)

Art.-No.		
71	17961611	Gas lens 17-18-26-220 / 1,6 45V25
71	17962411	Gas lens 17-18-26-220 / 2,4 45V26
71	18963211	Gas lens 17-18-26-220 / 3,2 45V27
72	17961021	Jumbo gas lens 17-18-26-220 / 1,0 45V0204
72	17961621	Jumbo gas lens 17-18-26-220 / 1,6 45V116
72	17962421	Jumbo gas lens 17-18-26-220 / 2,4 45V64
72	18963221	Jumbo gas lens 17-18-26-220 / 3,2 995795

**Brazen collets L-52mm
suitable equipment line (A) standard collet body
suitable equipment line (B) gas lens
suitable equipment line (D) gas lens jumbo**

75	17105202	Collet L52mm AS17-AS18-ABL220 / 1,0 10N22-D
75	17165202	Collet L52mm AS17-AS18-ABL220 / 1,6 10N23-D
75	17245202	Collet L52mm AS17-AS18-ABL220 / 2,4 10N24-D
75	18325202	Collet L52mm AS17-AS18-ABL220 / 3,2 10N25-D
78	17089021	PTFE-Gas-lens insulator 17-18-26-220 54N01
79	17089031	PTFE-Gas-lens insulator Jumbo 17-18-26-220 54N63

**Ceramic gas nozzles in different lengths
suitable equipment line (A) standard collet body**

80	17930401	Ceramic gas nozzle L47mm 17-18-26-220 / Gr.4 10N50 (pu=10pieces)
80	17930501	Ceramic gas nozzle L47mm 17-18-26-220 / Gr.5 10N49 (pu=10pieces)
80	17930601	Ceramic gas nozzle L47mm 17-18-26-220 / Gr.6 10N48 (pu=10pieces)
80	17930701	Ceramic gas nozzle L47mm 17-18-26-220 / Gr.7 10N47 (pu=10pieces)
80	17930801	Ceramic gas nozzle L47mm 17-18-26-220 / Gr.8 10N46 (pu=10pieces)
80	17930101	Ceramic gas nozzle L47mm 17-18-26-220 / Gr.10 10N45 (pu=10pieces)
80	17930121	Ceramic gas nozzle L47mm 17-18-26-220 / Gr.12 10N44 (pu=10pieces)
N.i.	17930404	Ceramic gas nozzle L76mm 17-18-26-220 / Gr.4 10N50L (pu=10pieces)
N.i.	17930504	Ceramic gas nozzle L76mm 17-18-26-220 / Gr.5 10N49L (pu=10pieces)
N.i.	17930604	Ceramic gas nozzle L76mm 17-18-26-220 / Gr.6 10N48L (pu=10pieces)
N.i.	17930704	Ceramic gas nozzle L76mm 17-18-26-220 / Gr.7 10N47L (pu=10pieces)

**Ceramic gas nozzles different lengths
suitable equipment line (B) gas lens
suitable equipment line (G) standard Retro 220**

90	22093041	Gas nozzle for gas lens L42mm / Gr.4 54N18 (pu=10pieces)
90	22093051	Gas nozzle for gas lens L42mm / Gr.5 54N17 (pu=10pieces)
90	22093061	Gas nozzle for gas lens L42mm / Gr.6 54N16 (pu=10pieces)
90	22093071	Gas nozzle for gas lens L42mm / Gr.7 54N15 (pu=10pieces)
90	22093081	Gas nozzle for gas lens L42mm / Gr.8 54N14 (pu=10pieces)
90	22093111	Gas nozzle for gas lens L42mm / Gr.11 54N19-11 (pu=10pieces)
90	22093121	Gas nozzle for gas lens L42mm / Gr.12 54N19 (pu=10pieces)
N.i.	22093054	Gas nozzle for gas lens L76mm / Gr.5 54N17L (pu=10pieces)
N.i.	22093064	Gas nozzle for gas lens L76mm / Gr.6 54N16L (pu=10pieces)
N.i.	22093074	Gas nozzle for gas lens L76mm / Gr.7 54N15L (pu=10pieces)
N.i.	22093084	Gas nozzle for gas lens L76mm / Gr.8 54N14L (pu=10pieces)

Welding-torch TIG gas-cooled

240A at 100% duty cycle (DC) - 200A at 100% duty cycle (AC)

Art.-No.

**Ceramic gas nozzles jumbo in different lengths
suitable equipment line (D) gas lens jumbo**

95	22093066	Jumbo gas nozzle L48mm / Gr.6 57N75	(pu=10pieces)
95	22093086	Jumbo gas nozzle L48mm / Gr.8 57N74	(pu=10pieces)
95	22093106	Jumbo gas nozzle L48mm / Gr.10 53N88	(pu=10pieces)
95	22093126	Jumbo gas nozzle L48mm / Gr.12 53N87	(pu=10pieces)
N.i.	22093067	Jumbo gas nozzle L73mm / Gr.6 57N75L	(pu=10pieces)
N.i.	22093087	Jumbo gas nozzle L73mm / Gr.8 57N74L	(pu=10pieces)
N.i.	22093107	Jumbo gas nozzle L73mm / Gr.10 53N88L	(pu=10pieces)
N.i.	22093127	Jumbo gas nozzle L73mm / Gr.12 53N87L	(pu=10pieces)

Top quality tungsten electrodes in 9 different qualities, see appendix A.

Torch 12-1-TW water-cooled



Holch Schweißbrenner GmbH
Bühlstraße 14
D-57080 Siegen

Phone: +49(0)271 387860-11
Telefax: +49(0)271 387860-29
E-Mail: info@holch-siegen.de
Web: www.holch-siegen.de



12-1-TW water-cooled

350 Ampere at 100% duty cycle (DC) - 260 Ampere at 100% duty cycle (AC)

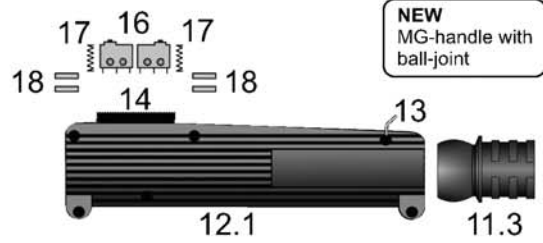
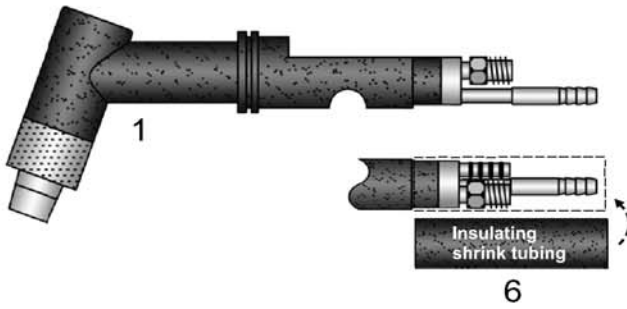

Forma WIG-handle with ball joint and different modular switch units

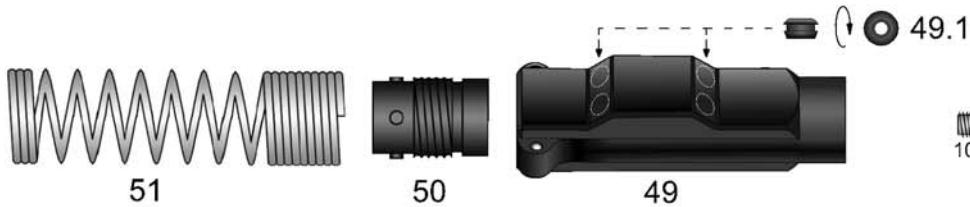
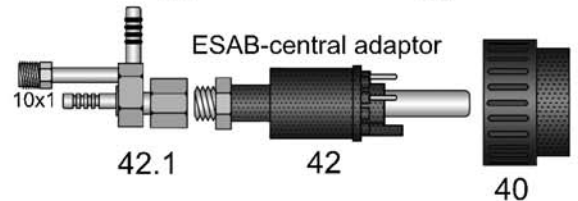
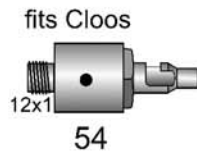
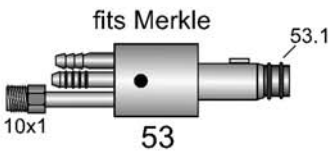
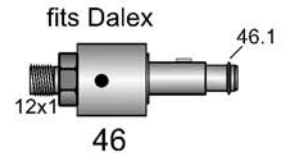
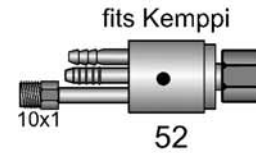
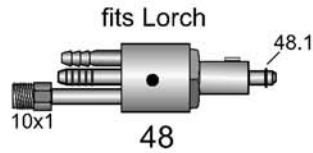
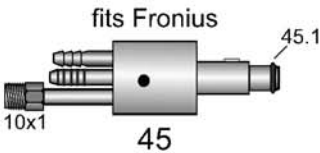
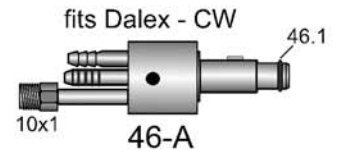
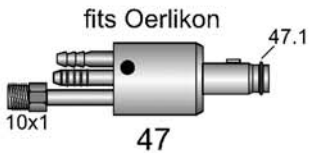
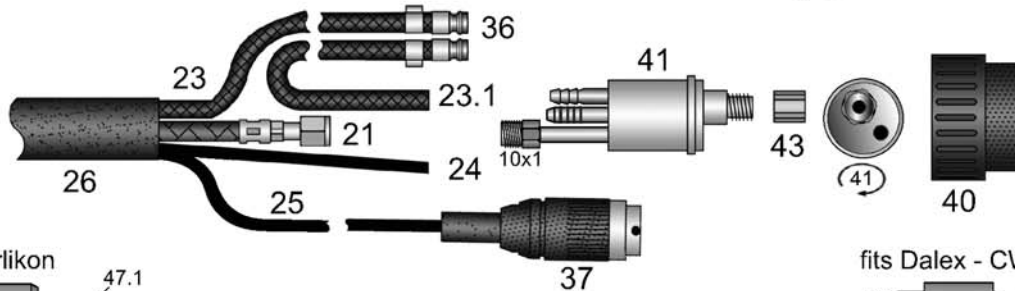

HSN 520



Equipment: **A** standard
B gas lens Holch
D gas lens jumbo
E gas lens mini

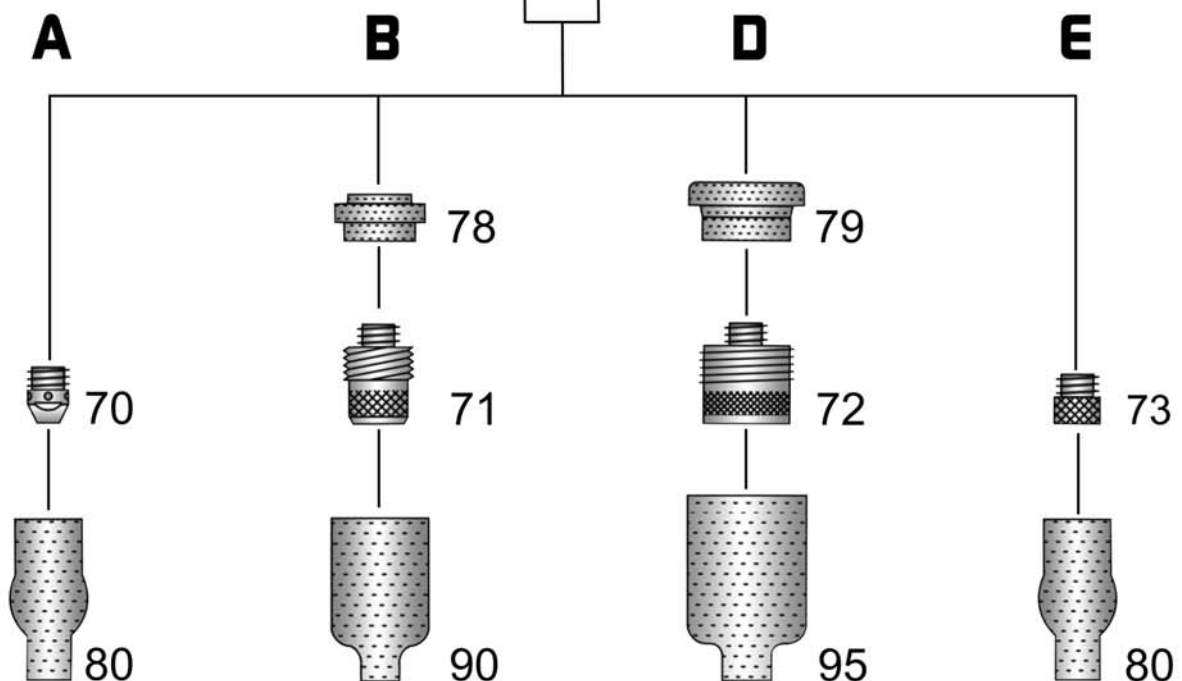
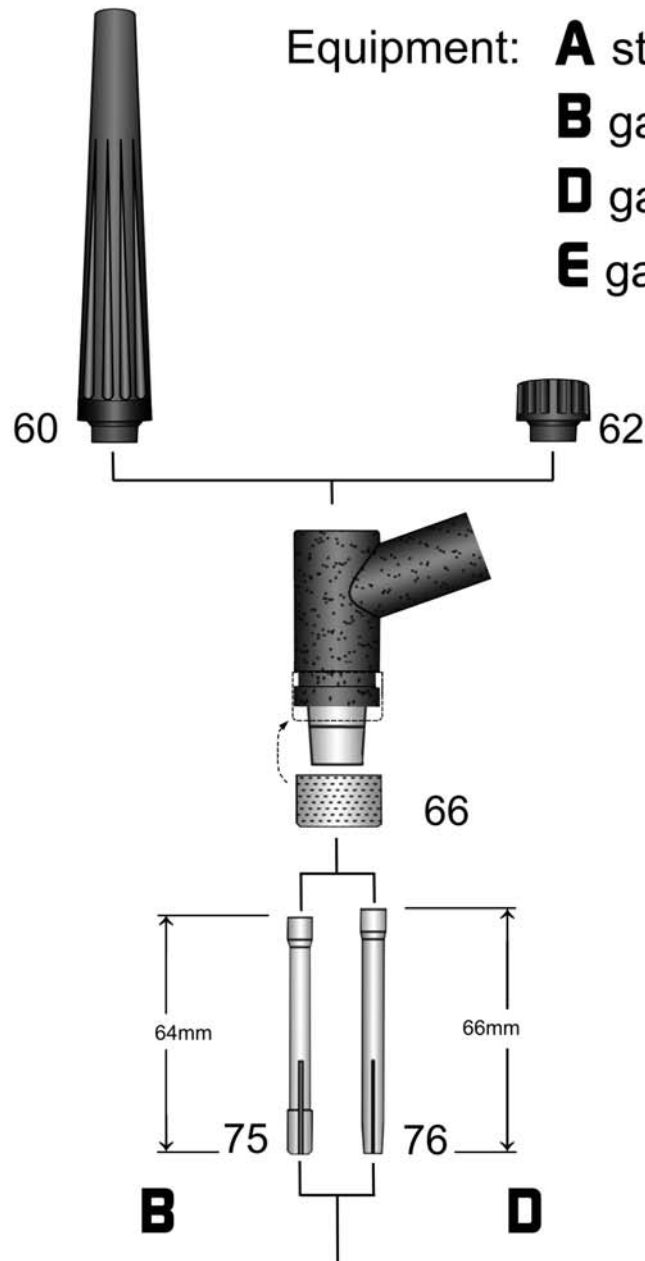

Welding-torch TIG water-cooled**350A at 100% duty cycle (DC) - 260A at 100% duty cycle (AC)****Art.-No.**

Torches with first meter leather hose. Prices without leather on request. Machine side separate connections with Tuchel plug.

In variation to the torches listed below, the torches can also be produced with other power/water cables (e.g. HT 180 silicone superflexible). This can also be combined with hoses in a lot of different qualities. Torches and cable assemblies can be produced in excess lengths. Please find the different options and surcharges in the attachment "Custom made products" appendix C. We produce torches for more than 40 different brands of machines with different connection systems.

12300401	Torch 12-1-TW / 4m spare cable assembly ST 80 PVC-NIT
----------	---

12300801	Torch 12-1-TW / 8m spare cable assembly ST 80 PVC-NIT
----------	---

The following torches are equipped with very flexible and heat resistant HT110 rubber fabric hoses.

1230040P	Torch 12-1-TW-PLUS / 4m spare cable assembly HT 110
----------	---

1230080P	Torch 12-1-TW-PLUS / 8m spare cable assembly HT 110
----------	---

TIG-spare cable assemblies in different qualities, machine side with separate connections and Tuchel plug, or, if ordered so, with the following connection systems:

wig92402	TIG-spare cable assembly water-cooled 4m - please state desired design!
----------	---

wig92802	TIG-spare cable assembly water-cooled 8m - please state desired design!
----------	---

The following surcharges for machine side connections are only to find prices quickly. Please use our catalogue "TIG machine side connections" to find a "T"number which identifies a machine side connection system completely.

29002102	Surcharge: machine side power/water plug SK35 bayonet connection AD13mm
----------	---

29000201	Surcharge: machine side with EURO central adapter
----------	---

29002109	Surcharge: machine side power/water plug fits Merkle with 2 O-rings
----------	---

29002106	Surcharge: machine side power/water plug fits Fronius with 1 O-ring
----------	---

29002101	Surcharge: machine side power/water plug fits Dalex with 1 O-ring
----------	---

29002108	Surcharge: machine side power/water plug fits Oerlikon with 1 O-ring
----------	--

29002104	Surcharge: machine side power/water plug fits Lorch SK35 + gas-nipple
----------	---

29002105	Surcharge: machine side power/water plug fits Kemppi IT-G1/4"
----------	---

29002110	Surcharge: machine side power/water plug fits Cloos
----------	---

29000212	Surcharge: machine side fits ESAB central adapter, 4 pins installed at position 3,4,5,6
----------	---

poti2901	Surcharge: 1 button with additional potentiometer
----------	---

ud290001	Surcharge: 4 switches > up / down
----------	-----------------------------------

Please note that there might be additional charges for special control line plugs. See appendix D.

1	12391001	Torch body 12-1-TW
---	----------	--------------------

6	18050002	Ignition insulating hose L75mm / ID39mm down to ID13mm
---	----------	--

11.1	91914601	Forma TIG handle with screws, ball joint, without modular switch unit
------	----------	---

11.2	91914602	Forma screw for handle
------	----------	------------------------

11.3	91914603	Forma hose bracket with ball joint ID21,5mm (also fits MG-handle)
------	----------	---

11.4	91914611	Forma modular switch unit: 1 button with connecting adapter
------	----------	---

11.5	91914621	Forma modular switch unit: 2 buttons with connecting adapter
------	----------	--

11.6	91914631	Forma modular switch unit: 1 button + potentiometer (10k) with connecting adapter
------	----------	---

11.7	91914641	Forma modular switch unit: 2 buttons + up/down (4 switches) with connecting adapter
------	----------	---

11.8	91914651	Forma connecting adapter fits control line to modular switch unit
------	----------	---

Welding-torch TIG water-cooled**350A at 100% duty cycle (DC) - 260A at 100% duty cycle (AC)**

Art.-No.		
N.i.	91914661	Forma switch module safety nipple
12.1	91914061	MG-handle with ball joint, push-button, 2 return springs, 2 microswitches and 4 cylindrical pins
13	91914421	MG-tapping screw
14	91915002	MG-push button
16	91914121	MG-microswitch
17	91914221	MG-return spring
18	91914321	MG-cylindrical pin

Please state the machine side connection for the following power/water cables.**For 4m long torches:**

20	12942401	ST 80 PVC-NIT power/water cable 10mm ² 12/18/20-TW / 4m
20	12942404	HT 105 PVC-NIT power/water cable 10mm ² 12/18/20-TW / 4m
20	12942403	HT 110 rubber fabric hose power/water cable 10mm ² 12/18/20-TW / 4m
20	12942405	HT 130 TPE power/water cable 10mm ² 12/18/20-TW / 4m
20	12942408	HT 180 silicone super flexible power/water cable 10mm ² 12/18/20-TW / 4m

For 8m long torches:

20	12942801	ST 80 PVC-NIT power/water cable 10mm ² 12/18/20-TW / 8m
20	12942804	HT 105 PVC-NIT power/water cable 10mm ² 12/18/20-TW / 8m
20	12942803	HT 110 Rubber fabric hose power/water cable 10mm ² 12/18/20-TW / 8m
20	12942805	HT 130 TPE power/water cable 10mm ² 12/18/20-TW / 8m
20	12942808	HT 180 silicone super flexible power/water cable 10mm ² 12/18/20-TW / 8m

The following power/water cables are produced with M10x1 inner thread at the machine side for EURO central adapters. (fits to all Holch connection systems with outer thread M10x1).**For 4m long torches:**

21	12942411	ST 80 PVC-NIT power/water cable 10mm ² 12/18/20-TW / 4m
21	12942414	HT 105 PVC-NIT power/water cable 10mm ² 12/18/20-TW / 4m
21	12942413	HT 110 rubber fabric hose power/water cable 10mm ² 12/18/20-TW / 4m
21	12942415	HT 130 TPE power/water cable 10mm ² 12/18/20-TW / 4m
21	12942418	HT 180 silicone super flexible power/water cable 10mm ² 12/18/20-TW / 4m

For 8m long torches:

21	12942811	ST 80 PVC-NIT power/water cable 10mm ² 12/18/20-TW / 8m
21	12942814	HT 105 PVC-NIT power/water cable 10mm ² 12/18/20-TW / 8m
21	12942813	HT 110 rubber fabric hose power/water cable 10mm ² 12/18/20-TW / 8m
21	12942815	HT 130 TPE power/water cable 10mm ² 12/18/20-TW / 8m
21	12942818	HT 180 silicone super flexible power/water cable 10mm ² 12/18/20-TW / 8m

Reel goods:**Prices are per meter and only applicable for purchasing of complete rolls**

23	50150001	Meter ST 80 PVC-NIT fabric hose ID5,0-W1,5mm blue for water (100m)
23	51700002	Meter HT 110 rubber fabric hose ID5,0-W1,7mm blue for water (100m)
23.1	50151001	Meter ST 80 PVC-NIT fabric hose ID5,0-W1,5mm red for water (100m)
23.1	51700003	Meter HT 110 rubber fabric hose ID5,0-W1,7mm red for water (100m)
24	31000001	Meter ST 70 PVC hose ID3,0-W1,0mm black for gas (100m)
24	51700001	Meter HT 110 rubber fabric hose ID5,0-W1,7mm black for gas (100m)
24	31200001	Meter HT 130 PUR hose ID3-W1,2mm black for gas (100m)

N.i.	91902701	Meter control line 3x0,34mm ² shielded black (100m)
N.i.	91902711	Meter control line 3x0,5mm ² red (100m)
25	91902721	Meter control line 5x0,25mm ² grey (100m)

Welding-torch TIG water-cooled**350A at 100% duty cycle (DC) - 260A at 100% duty cycle (AC)**

Art.-No.		
26	22150002	Meter neoprene protective hose ID22mm black (40m)
N.i.	91915004	Leather protective hose ID22mm / 1 meter long
N.i.	91915007	Leather protective hose ID22mm / 1 meter long with ball joint and hose connector
N.i.	91915003	Hose connector leather protective hose / protection hose ID19,5mm
34	91901501	Coupling nut IT-G1/4"
N.i.	91901211	Hose connector 4mm fits coupling nut R1/4"
35	91901601	Coupling nut IT-G3/8"
N.i.	91901301	Hose connector 5mm fits Coupling nut R3/8"
36	91901001	Cooling liquid plug nipples EURO
N.i.	91901008	Closing cap blue fits cooling liquid plug nipples EURO
N.i.	91901009	Closing cap red fits cooling liquid plug nipples EURO
37	91904101	Plug 3-poles Tuchel with bayonet-catch
37	91904111	Plug 5-poles Tuchel with bayonet-catch
More control line plugs see appendix D		
40	91900701	Terminal nut insulated fits EURO central adapter
41	91900211	TIG central adapter EURO central adapter water cooled
42	91900301	TIG central adapter identical ESAB, 4 contact pins at position 3,4,5,6
42.1	91918571	TIG power/cooling liquid junction fits ESAB central adapter
42.3	91918312	TIG central adapter SK-35 bayonet connection AD13mm
43	91900901	Coupling nut IT-M10x1 (rounded edges) fits EURO central adapter
45	91918327	Power/water plug fits Fronius with 1 O-ring (OT-M10x1 / like EURO central adapter)
45.1	62190001	O-ring ID6,2-W1,9mm fits Fronius
46	9190417e	Power/water plug fits Dalex (1 O-ring) (OT-12x1)
46-A	9190418n	Power-/gasplug fits Dalex with waterdeviation to outside, CW-System with 1 O-ring
46.1	63240001	O-ring ID6,3-W2,4mm fits Dalex
47	9190423n	Power/water plug fits Oerlikon with 1 O-ring (OT-M10x1 / like EURO central adapter)
47.1	60717801	O-ring ID6,07-W1,78mm fits Oerlikon
48	9190420n	Power/water plug fits Lorch SK35 + gas-nipple (OT-10x1 / like EURO central adapter)
48.1	91900801	O-ring ID4-W1mm fits gas-nipple EURO central adapter
N.i.	91900552	TIG cable support long (like MIG-MAG) with screws fits ESAB central adapter
N.i.	91900554	Attachment screw M4x8mm fits ESAB central adapter
49	91900557	TIG cable support short with screws (fits water-cooled)
N.i.	91920702	Screw M3x11,5mm for Ratio/Industry/RAUCH handle and cable support
N.i.	91920703	M3 mounting socket for Ratio/Industry/RAUCH handle and cable support
o.A.	91900602	Screw M4x6mm for TIG cable support short
49.1	91901012	Reduction-eyelet (rubber) from ID10,5mm to ID5mm fits TIG cable support short
N.i.	91921701	PUR hose ID8,5-W1,0mm 150mm long fits leading water hoses into cable support
50	91912801	Spring-socket EURO central adapter
51	91912601	Cable support spring fits EURO / ESAB central adapter
52	9190419n	Power/water plug fits Kemppi IT-G1/4" (AG-M10x1 / like EURO central adapter)
53	9190424n	Power/water plug fits Merkle with 2 O-rings (OT-M10x1 / like EURO central adapter)
53.1	81600001	O-ring ID8-W1,6mm fits Lorch/Merkle
54	9190415n	Powerplug fits Cloos (special-plug) (OT-12x1)

Welding-torch TIG water-cooled**350A at 100% duty cycle (DC) - 260A at 100% duty cycle (AC)**

Art.-No.		
60	12391311	Back cap long 12-1-TW
62	12391301	Back cap short 12-1-TW
66	12389001	PTFE-isolator 12-1-TW 200NGR
70	12396161	Collet body 12-1-TW / 1,6
70	12396241	Collet body 12-1-TW / 2,4
70	12396321	Collet body 12-1-TW / 3,2
70	12396401	Collet body 12-1-TW / 4,0
71	12396162	Gas lens large 12-1-TW / 1,6
71	12396242	Gas lens large 12-1-TW / 2,4
71	12396322	Gas lens large 12-1-TW / 3,2
71	12396402	Gas lens large 12-1-TW / 4,0
72	12396164	Jumbo gas lens 12-1-TW / 1,6
72	12396244	Jumbo gas lens 12-1-TW / 2,4
72	12396324	Jumbo gas lens 12-1-TW / 3,2
72	12396404	Jumbo gas lens 12-1-TW / 4,0
73	12396163	Mini-Gas lens 12-1-TW / 1,6
73	12396243	Mini-Gas lens 12-1-TW / 2,4
73	12396323	Mini-Gas lens 12-1-TW / 3,2
73	12396403	Mini-Gas lens 12-1-TW / 4,0
Brazen-collets L-64mm suitable equipment line (A) standard collet body suitable equipment line (B) gas lens Holch suitable equipment line (E) gas lens mini		
75	12166401	Collet L64mm 12-1-TW / 1,6 (triple dagged)
75	12246401	Collet L64mm 12-1-TW / 2,4 (triple dagged)
75	12326401	Collet L64mm 12-1-TW / 3,2 (triple dagged)
75	12406401	Collet L64mm 12-1-TW / 4,0 (triple dagged)
Brazen-collets L-66mm suitable equipment line (A) standard collet body suitable equipment line (B) gas lens Holch suitable equipment line (D) jumbo gas lens suitable equipment line (E) gas lens mini		
76	12166601	Collet L66mm 12-1-TW / 1,6 for Jumbo gas lens
76	12246601	Collet L66mm 12-1-TW / 2,4 for Jumbo gas lens
76	12326601	Collet L66mm 12-1-TW / 3,2 for Jumbo gas lens
76	12406601	Collet L66mm 12-1-TW / 4,0 for Jumbo gas lens
78	12389011	PTFE-Gas-lens insulator for gas lens large 12-1-TW
79	12389021	PTFE-Gas-lens insulator Jumbo 12-1-TW
Ceramic gas nozzles L-44mm suitable equipment line (A) standard collet body suitable equipment line (E) gas lens mini		
80	12393041	Ceramic gas nozzle L44mm 12-1-TW / Gr.4 130.00 (pu=10pieces)
80	12393051	Ceramic gas nozzle L44mm 12-1-TW / Gr.5 131.00 (pu=10pieces)

Welding-torch TIG water-cooled**350A at 100% duty cycle (DC) - 260A at 100% duty cycle (AC)**

Art.-No.					
80	12393061	Ceramic gas nozzle L44mm	12-1-TW / Gr.6	132.00	(pu=10pieces)
80	12393071	Ceramic gas nozzle L44mm	12-1-TW / Gr.7	133.00	(pu=10pieces)
80	12393081	Ceramic gas nozzle L44mm	12-1-TW / Gr.8	134.00	(pu=10pieces)
80	12393091	Ceramic gas nozzle L44mm	12-1-TW / Gr.9	135.00	(pu=10pieces)
80	12393101	Ceramic gas nozzle L44mm	12-1-TW / Gr.10	136.00	(pu=10pieces)
80	12393121	Ceramic gas nozzle L44mm	12-1-TW / Gr.12	137.00	(pu=10pieces)

**Ceramic gas nozzles different lengths
suitable equipment line (B) gas lens Holch**

90	22093041	Gas nozzle for gas lens L42mm / Gr.4	54N18	(pu=10pieces)
90	22093051	Gas nozzle for gas lens L42mm / Gr.5	54N17	(pu=10pieces)
90	22093061	Gas nozzle for gas lens L42mm / Gr.6	54N16	(pu=10pieces)
90	22093071	Gas nozzle for gas lens L42mm / Gr.7	54N15	(pu=10pieces)
90	22093081	Gas nozzle for gas lens L42mm / Gr.8	54N14	(pu=10pieces)
90	22093111	Gas nozzle for gas lens L42mm / Gr.11	54N19-11	(pu=10pieces)
90	22093121	Gas nozzle for gas lens L42mm / Gr.12	54N19	(pu=10pieces)

N.i.	22093054	Gas nozzle for gas lens L76mm / Gr.5	54N17L	(pu=10pieces)
N.i.	22093064	Gas nozzle for gas lens L76mm / Gr.6	54N16L	(pu=10pieces)
N.i.	22093074	Gas nozzle for gas lens L76mm / Gr.7	54N15L	(pu=10pieces)
N.i.	22093084	Gas nozzle for gas lens L76mm / Gr.8	54N14L	(pu=10pieces)

**Ceramic gas nozzles jumbo in different lengths
suitable equipment line (D) gas lens jumbo**

95	22093066	Jumbo gas nozzle L48mm / Gr.6	57N75	(pu=10pieces)
95	22093086	Jumbo gas nozzle L48mm / Gr.8	57N74	(pu=10pieces)
95	22093106	Jumbo gas nozzle L48mm / Gr.10	53N88	(pu=10pieces)
95	22093126	Jumbo gas nozzle L48mm / Gr.12	53N87	(pu=10pieces)

N.i.	22093067	Jumbo gas nozzle L73mm / Gr.6	57N75L	(pu=10pieces)
N.i.	22093087	Jumbo gas nozzle L73mm / Gr.8	57N74L	(pu=10pieces)
N.i.	22093107	Jumbo gas nozzle L73mm / Gr.10	53N88L	(pu=10pieces)
N.i.	22093127	Jumbo gas nozzle L73mm / Gr.12	53N87L	(pu=10pieces)

Top quality tungsten electrodes in 9 different qualities, see appendix A.

Torch AS 18-TW water-cooled



Holch Schweißbrenner GmbH
Bühlstraße 14
D-57080 Siegen

Phone: +49(0)271 387860-11
Telefax: +49(0)271 387860-29
E-Mail: info@holch-siegen.de
Web: www.holch-siegen.de



AS 18-TW water-cooled

320 Ampere at 100% duty cycle (DC) - 240 Ampere at 100% duty cycle (AC)

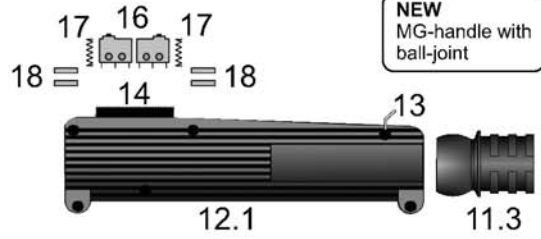
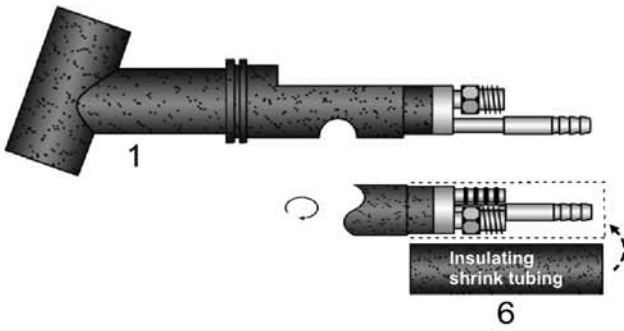

Forma WIG-handle with ball joint and different modular switch units

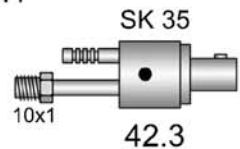
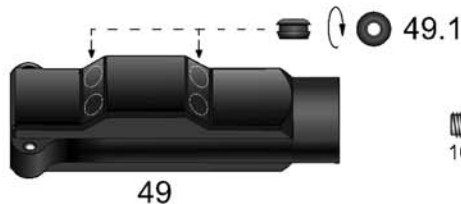
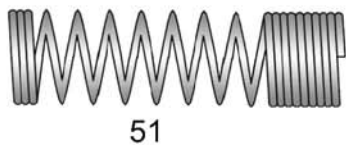
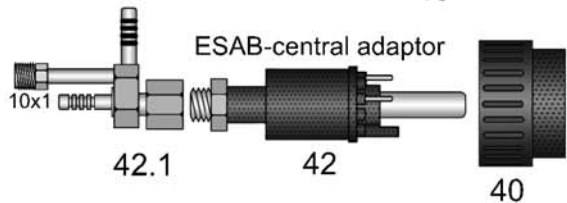
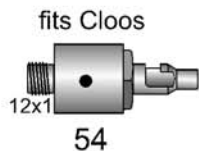
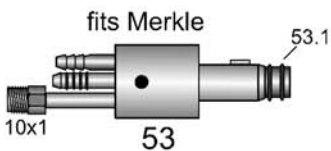
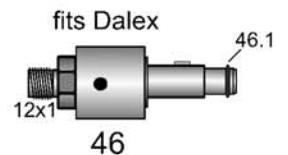
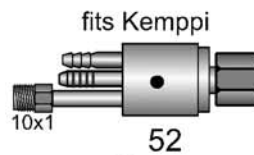
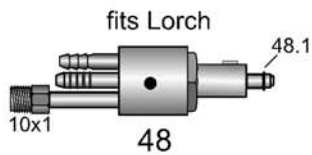
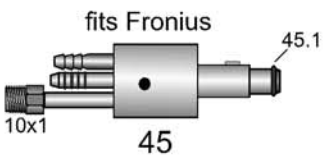
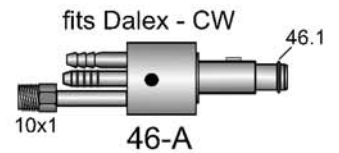
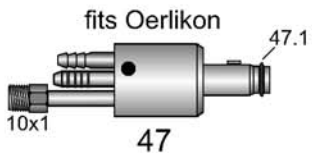
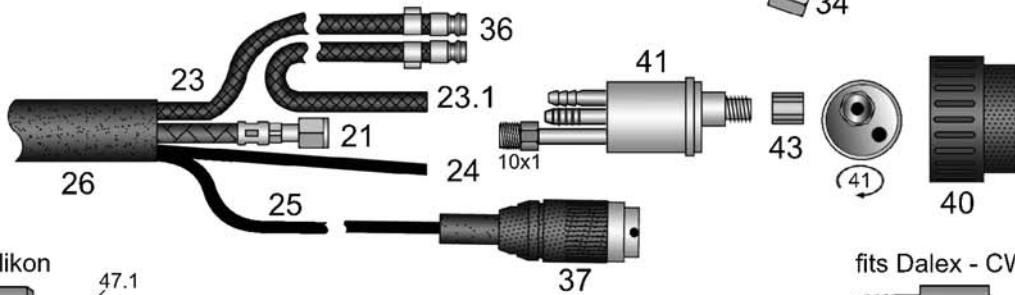

HSN 525



Equipment: **A** standard
B gas lens
D gas lens jumbo

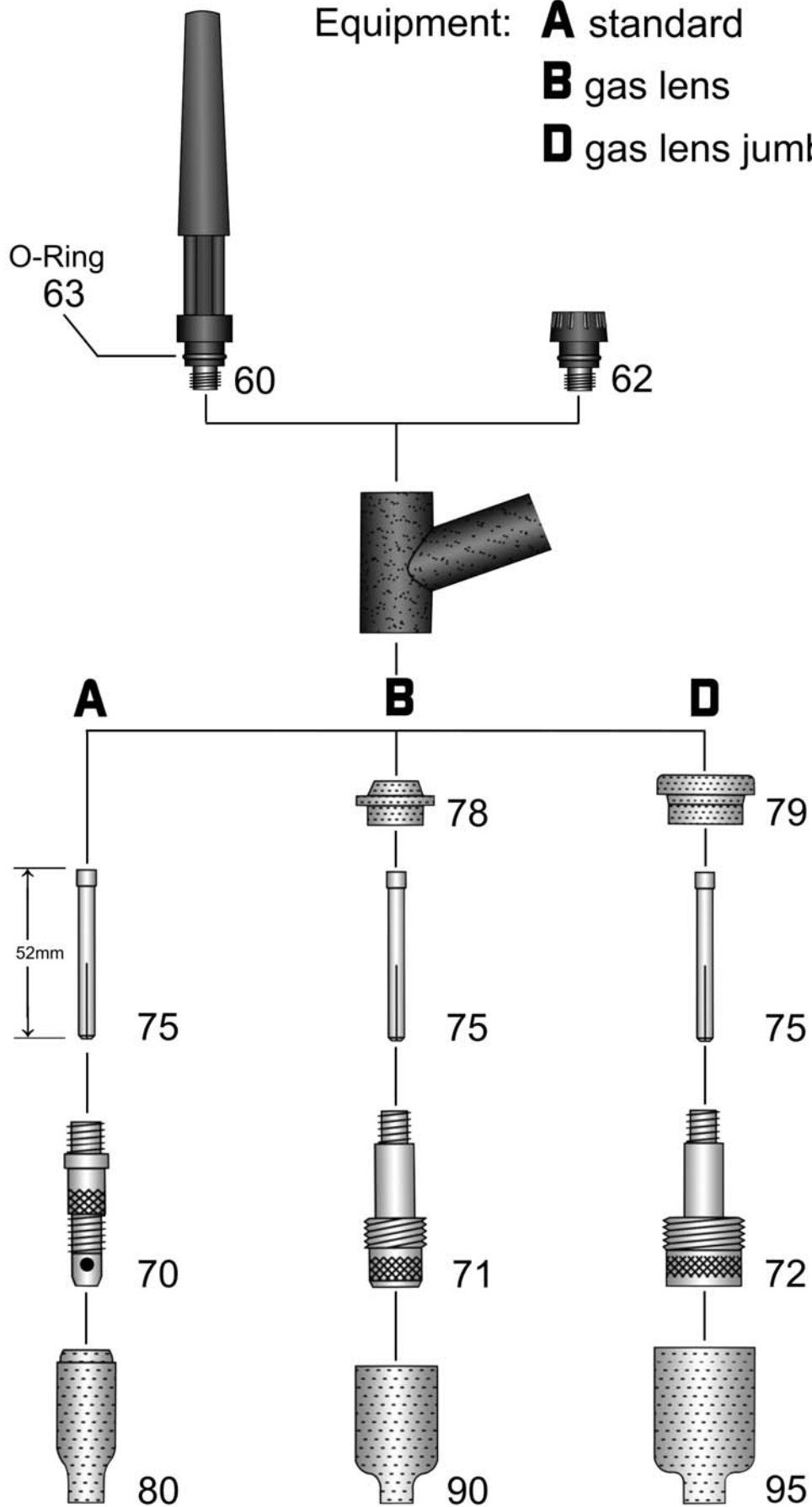

Welding-torch TIG water-cooled**320A at 100% duty cycle (DC) - 240A at 100% duty cycle (AC)****Art.-No.**

Torches with first meter leather hose. Prices without leather on request. Machine side separate connections with Tuchel plug.

In variation to the torches listed below, the torches can also be produced with other power/water cables (e.g. HT 180 silicone superflexible). This can also be combined with hoses in a lot of different qualities. Torches and cable assemblies can be produced in excess lengths. Please find the different options and surcharges in the attachment "Custom made products" appendix C. We produce torches for more than 40 different brands of machines with different connection systems.

18600401 Torch AS 18-TW / 4m spare cable assembly ST 80 PVC-NIT

18600801 Torch AS 18-TW / 8m spare cable assembly ST 80 PVC-NIT

The following torches are equipped with very flexible and heat resistant HT110 rubber fabric hoses.

1860040P Torch AS 18-TW / 4m spare cable assembly HT 110

1860080P Torch AS 18-TW / 8m spare cable assembly HT 110

TIG-spare cable assemblies in different qualities, machine side with separate connections and Tuchel plug, or, if ordered so, with the following connection systems:

wig92402 TIG-spare cable assembly water-cooled 4m - please state desired design!

wig92802 TIG-spare cable assembly water-cooled 8m - please state desired design!

The following surcharges for machine side connections are only to find prices quickly. Please use our catalogue "TIG machine side connections" to find a "T" number which identifies a machine side connection system completely.

29002102 Surcharge: machine side power/water plug SK35 bayonet connection AD13mm

29000201 Surcharge: machine side with EURO central adapter

29002109 Surcharge: machine side power/water plug fits Merkle with 2 O-rings

29002106 Surcharge: machine side power/water plug fits Fronius with 1 O-ring

29002101 Surcharge: machine side power/water plug fits Dalex with 1 O-ring

29002108 Surcharge: machine side power/water plug fits Oerlikon with 1 O-ring

29002104 Surcharge: machine side power/water plug fits Lorch SK35 + gas-nipple

29002105 Surcharge: machine side power/water plug fits Kemppi IT-G1/4"

29002110 Surcharge: machine side power/water plug fits Cloos

29000212 Surcharge: machine side fits ESAB central adapter, 4 pins installed at position 3,4,5,6

poti2901 Surcharge: 1 button with additional potentiometer

ud290001 Surcharge: 4 switches > up / down

Please note that there might be additional charges for special control line plugs. See appendix D.

1 18691001 Torch body AS 18-TW

6 18050002 Ignition insulating hose L75mm / ID39mm down to ID13mm

11.1 91914601 Forma TIG handle with screws, ball joint, without modular switch unit

11.2 91914602 Forma screw for handle

11.3 91914603 Forma hose bracket with ball joint ID21,5mm (also fits MG-handle)

11.4 91914611 Forma modular switch unit: 1 button with connecting adapter

11.5 91914621 Forma modular switch unit: 2 buttons with connecting adapter

11.6 91914631 Forma modular switch unit: 1 button + potentiometer (10k) with connecting adapter

11.7 91914641 Forma modular switch unit: 2 buttons + up/down (4 switches) with connecting adapter

11.8 91914651 Forma connecting adapter fits control line to modular switch unit

N.i. 91914661 Forma switch module safety nipple

Welding-torch TIG water-cooled**320A at 100% duty cycle (DC) - 240A at 100% duty cycle (AC)**

Art.-No.		
12.1	91914061	MG-handle with ball joint, push-button, 2 return springs, 2 microswitches and 4 cylindrical pins
13	91914421	MG-tapping screw
14	91915002	MG-push button
16	91914121	MG-microswitch
17	91914221	MG-return spring
18	91914321	MG-cylindrical pin
Please state the machine side connection for the following power/water cables.		
For 4m long torches:		
20	12942401	ST 80 PVC-NIT power/water cable 10mm ² 12/18/20-TW / 4m
20	12942404	HT 105 PVC-NIT power/water cable 10mm ² 12/18/20-TW / 4m
20	12942403	HT 110 rubber fabric hose power/water cable 10mm ² 12/18/20-TW / 4m
20	12942405	HT 130 TPE power/water cable 10mm ² 12/18/20-TW / 4m
20	12942408	HT 180 silicone super flexible power/water cable 10mm ² 12/18/20-TW / 4m
For 8m long torches:		
20	12942801	ST 80 PVC-NIT power/water cable 10mm ² 12/18/20-TW / 8m
20	12942804	HT 105 PVC-NIT power/water cable 10mm ² 12/18/20-TW / 8m
20	12942803	HT 110 Rubber fabric hose power/water cable 10mm ² 12/18/20-TW / 8m
20	12942805	HT 130 TPE power/water cable 10mm ² 12/18/20-TW / 8m
20	12942808	HT 180 silicone super flexible power/water cable 10mm ² 12/18/20-TW / 8m
The following power/water cables are produced with M10x1 inner thread at the machine side for EURO central adapters. (fits to all Holch connection systems with outer thread M10x1).		
For 4m long torches:		
21	12942411	ST 80 PVC-NIT power/water cable 10mm ² 12/18/20-TW / 4m
21	12942414	HT 105 PVC-NIT power/water cable 10mm ² 12/18/20-TW / 4m
21	12942413	HT 110 rubber fabric hose power/water cable 10mm ² 12/18/20-TW / 4m
21	12942415	HT 130 TPE power/water cable 10mm ² 12/18/20-TW / 4m
21	12942418	HT 180 silicone super flexible power/water cable 10mm ² 12/18/20-TW / 4m
For 8m long torches:		
21	12942811	ST 80 PVC-NIT power/water cable 10mm ² 12/18/20-TW / 8m
21	12942814	HT 105 PVC-NIT power/water cable 10mm ² 12/18/20-TW / 8m
21	12942813	HT 110 rubber fabric hose power/water cable 10mm ² 12/18/20-TW / 8m
21	12942815	HT 130 TPE power/water cable 10mm ² 12/18/20-TW / 8m
21	12942818	HT 180 silicone super flexible power/water cable 10mm ² 12/18/20-TW / 8m
Reel goods:		
Prices are per meter and only applicable for purchasing of complete rolls		
23	50150001	Meter ST 80 PVC-NIT fabric hose ID5,0-W1,5mm blue for water (100m)
23	51700002	Meter HT 110 rubber fabric hose ID5,0-W1,7mm blue for water (100m)
23.1	50151001	Meter ST 80 PVC-NIT fabric hose ID5,0-W1,5mm red for water (100m)
23.1	51700003	Meter HT 110 rubber fabric hose ID5,0-W1,7mm red for water (100m)
24	31000001	Meter ST 70 PVC hose ID3,0-W1,0mm black for gas (100m)
24	51700001	Meter HT 110 rubber fabric hose ID5,0-W1,7mm black for gas (100m)
24	31200001	Meter HT 130 PUR hose ID3-W1,2mm black for gas (100m)
N.i.	91902701	Meter control line 3x0,34mm ² shielded black (100m)
N.i.	91902711	Meter control line 3x0,5mm ² red (100m)
25	91902721	Meter control line 5x0,25mm ² grey (100m)
26	22150002	Meter neoprene protective hose ID22mm black (40m)

Welding-torch TIG water-cooled**320A at 100% duty cycle (DC) - 240A at 100% duty cycle (AC)**

Art.-No.		
N.i.	91915004	Leather protective hose ID22mm / 1 meter long
N.i.	91915007	Leather protective hose ID22mm / 1 meter long with ball joint and hose connector
N.i.	91915003	Hose connector leather protective hose / protection hose ID19,5mm
34	91901501	Coupling nut IT-G1/4"
N.i.	91901211	Hose connector 4mm fits coupling nut R1/4"
35	91901601	Coupling nut IT-G3/8"
N.i.	91901301	Hose connector 5mm fits Coupling nut R3/8"
36	91901001	Cooling liquid plug nipples EURO
N.i.	91901008	Closing cap blue fits cooling liquid plug nipples EURO
N.i.	91901009	Closing cap red fits cooling liquid plug nipples EURO
37	91904101	Plug 3-poles Tuchel with bayonet-catch
37	91904111	Plug 5-poles Tuchel with bayonet-catch
More control line plugs see appendix D		
40	91900701	Terminal nut insulated fits EURO central adapter
41	91900211	TIG central adapter EURO central adapter water cooled
42	91900301	TIG central adapter identical ESAB, 4 contact pins at position 3,4,5,6
42.1	91918571	TIG power/cooling liquid junction fits ESAB central adapter
42.3	91918312	TIG central adapter SK-35 bayonet connection AD13mm
43	91900901	Coupling nut IT-M10x1 (rounded edges) fits EURO central adapter
45	91918327	Power/water plug fits Fronius with 1 O-ring (OT-M10x1 / like EURO central adapter)
45.1	62190001	O-ring ID6,2-W1,9mm fits Fronius
46	9190417e	Power/water plug fits Dalex (1 O-ring) (OT-12x1)
46-A	9190418n	Power-/gasplug fits Dalex with waterdeviation to outside, CW-System with 1 O-ring
46.1	63240001	O-ring ID6,3-W2,4mm fits Dalex
47	9190423n	Power/water plug fits Oerlikon with 1 O-ring (OT-M10x1 / like EURO central adapter)
47.1	60717801	O-ring ID6,07-W1,78mm fits Oerlikon
48	9190420n	Power/water plug fits Lorch SK35 + gas-nipple (OT-10x1 / like EURO central adapter)
48.1	91900801	O-ring ID4-W1mm fits gas-nipple EURO central adapter
o.A	91900552	TIG cable support long (like MIG-MAG) with screws fits ESAB central adapter
N.i.	91900554	Attachment screw M4x8mm fits ESAB central adapter
49	91900557	TIG cable support short with screws (fits water-cooled)
N.i.	91920702	Screw M3x11,5mm for Ratio/Industry/RAUCH handle and cable support
N.i.	91920703	M3 mounting socket for Ratio/Industry/RAUCH handle and cable support
o.A.	91900602	Screw M4x6mm for TIG cable support short
49.1	91901012	Reduction-eyelet (rubber) from ID10,5mm to ID5mm fits TIG cable support short
N.i.	91921701	PUR hose ID8,5-W1,0mm 150mm long fits leading water hoses into cable support
50	91912801	Spring-socket EURO central adapter
51	91912601	Cable support spring fits EURO / ESAB central adapter
52	9190419n	Power/water plug fits Kemppi IT-G1/4" (AG-M10x1 / like EURO central adapter)
53	9190424n	Power/water plug fits Merkle with 2 O-rings (OT-M10x1 / like EURO central adapter)
53.1	81600001	O-ring ID8-W1,6mm fits Lorch/Merkle
54	9190415n	Powerplug fits Cloos (special-plug) (OT-12x1)
60	17091311	Holch back cap long (german version with black O-ring) AS17-AS18-ABL220 57Y02-D

Welding-torch TIG water-cooled**320A at 100% duty cycle (DC) - 240A at 100% duty cycle (AC)**

Art.-No.		
62	17091301	Holch back cap short (german version with black O-ring) AS17-AS18-ABL220 57Y04-D
63	17089011	O-ring black ID9-W2,5mm for back cap
70	17961002	Collet body 17-18-26-220 / 1,0 10N30
70	17961602	Collet body 17-18-26-220 / 1,6 10N31
70	17962402	Collet body 17-18-26-220 / 2,4 10N32
70	18963202	Collet body 17-18-26-220 / 3,2 10N28
70	18964002	Collet body 17-18-26-220 / 4,0 406488
71	17961011	Gas lens 17-18-26-220 / 1,0 45V24
71	17961611	Gas lens 17-18-26-220 / 1,6 45V25
71	17962411	Gas lens 17-18-26-220 / 2,4 45V26
71	18963211	Gas lens 17-18-26-220 / 3,2 45V27
71	18964011	Gas lens 17-18-26-220 / 4,0 45V28
72	17961021	Jumbo gas lens 17-18-26-220 / 1,0 45V0204
72	17961621	Jumbo gas lens 17-18-26-220 / 1,6 45V116
72	17962421	Jumbo gas lens 17-18-26-220 / 2,4 45V64
72	18963221	Jumbo gas lens 17-18-26-220 / 3,2 995795
72	18964021	Jumbo gas lens 17-18-26-220 / 4,0 45V63

Brazen collets L-52mm**suitable equipment line (A) standard collet body****suitable equipment line (B) gas lens****suitable equipment line (D) gas lens jumbo**

75	17105202	Collet L52mm AS17-AS18-ABL220 / 1,0 10N22-D
75	17165202	Collet L52mm AS17-AS18-ABL220 / 1,6 10N23-D
75	17245202	Collet L52mm AS17-AS18-ABL220 / 2,4 10N24-D
75	18325202	Collet L52mm AS17-AS18-ABL220 / 3,2 10N25-D
75	18405202	Collet L52mm AS17-AS18-ABL220 / 4,0 54N20-D
78	17089021	PTFE-Gas-lens insulator 17-18-26-220 54N01
79	17089031	PTFE-Gas-lens insulator Jumbo 17-18-26-220 54N63

Ceramic gas nozzles in different lengths**suitable equipment line (A) standard collet body**

80	17930401	Ceramic gas nozzle L47mm 17-18-26-220 / Gr.4 10N50 (pu=10pieces)
80	17930501	Ceramic gas nozzle L47mm 17-18-26-220 / Gr.5 10N49 (pu=10pieces)
80	17930601	Ceramic gas nozzle L47mm 17-18-26-220 / Gr.6 10N48 (pu=10pieces)
80	17930701	Ceramic gas nozzle L47mm 17-18-26-220 / Gr.7 10N47 (pu=10pieces)
80	17930801	Ceramic gas nozzle L47mm 17-18-26-220 / Gr.8 10N46 (pu=10pieces)
80	17930101	Ceramic gas nozzle L47mm 17-18-26-220 / Gr.10 10N45 (pu=10pieces)
80	17930121	Ceramic gas nozzle L47mm 17-18-26-220 / Gr.12 10N44 (pu=10pieces)
N.i.	17930404	Ceramic gas nozzle L76mm 17-18-26-220 / Gr.4 10N50L (pu=10pieces)
N.i.	17930504	Ceramic gas nozzle L76mm 17-18-26-220 / Gr.5 10N49L (pu=10pieces)
N.i.	17930604	Ceramic gas nozzle L76mm 17-18-26-220 / Gr.6 10N48L (pu=10pieces)
N.i.	17930704	Ceramic gas nozzle L76mm 17-18-26-220 / Gr.7 10N47L (pu=10pieces)

Ceramic gas nozzles in different lengths**suitable equipment line (B) gas lens**

90	22093041	Gas nozzle for gas lens L42mm / Gr.4 54N18 (pu=10pieces)
90	22093051	Gas nozzle for gas lens L42mm / Gr.5 54N17 (pu=10pieces)

Welding-torch TIG water-cooled**320A at 100% duty cycle (DC) - 240A at 100% duty cycle (AC)**

Art.-No.		
90	22093061	Gas nozzle for gas lens L42mm / Gr.6 54N16 (pu=10pieces)
90	22093071	Gas nozzle for gas lens L42mm / Gr.7 54N15 (pu=10pieces)
90	22093081	Gas nozzle for gas lens L42mm / Gr.8 54N14 (pu=10pieces)
90	22093111	Gas nozzle for gas lens L42mm / Gr.11 54N19-11 (pu=10pieces)
90	22093121	Gas nozzle for gas lens L42mm / Gr.12 54N19 (pu=10pieces)
N.i.	22093054	Gas nozzle for gas lens L76mm / Gr.5 54N17L (pu=10pieces)
N.i.	22093064	Gas nozzle for gas lens L76mm / Gr.6 54N16L (pu=10pieces)
N.i.	22093074	Gas nozzle for gas lens L76mm / Gr.7 54N15L (pu=10pieces)
N.i.	22093084	Gas nozzle for gas lens L76mm / Gr.8 54N14L (pu=10pieces)

**Ceramic gas nozzles jumbo in different lengths
suitable equipment line (D) gas lens jumbo**

95	22093066	Jumbo gas nozzle L48mm / Gr.6 57N75 (pu=10pieces)
95	22093086	Jumbo gas nozzle L48mm / Gr.8 57N74 (pu=10pieces)
95	22093106	Jumbo gas nozzle L48mm / Gr.10 53N88 (pu=10pieces)
95	22093126	Jumbo gas nozzle L48mm / Gr.12 53N87 (pu=10pieces)
N.i.	22093067	Jumbo gas nozzle L73mm / Gr.6 57N75L (pu=10pieces)
N.i.	22093087	Jumbo gas nozzle L73mm / Gr.8 57N74L (pu=10pieces)
N.i.	22093107	Jumbo gas nozzle L73mm / Gr.10 53N88L (pu=10pieces)
N.i.	22093127	Jumbo gas nozzle L73mm / Gr.12 53N87L (pu=10pieces)

Top quality tungsten electrodes in 9 different qualities, see appendix A.

Torch SR 18-TW water-cooled



Holch Schweißbrenner GmbH
Bühlstraße 14
D-57080 Siegen

Phone: +49(0)271 387860-11
Telefax: +49(0)271 387860-29
E-Mail: info@holch-siegen.de
Web: www.holch-siegen.de



SR 18-TW water-cooled

320 Ampere at 100% duty cycle (DC) - 240 Ampere at 100% duty cycle (AC)

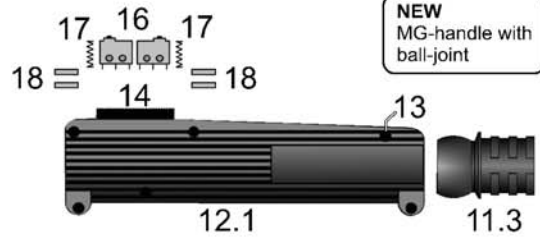
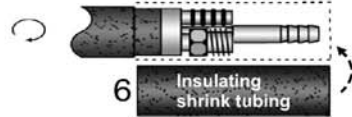

Forma WIG-handle with ball joint and different modular switch units

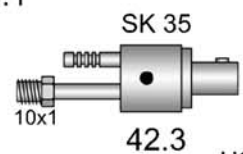
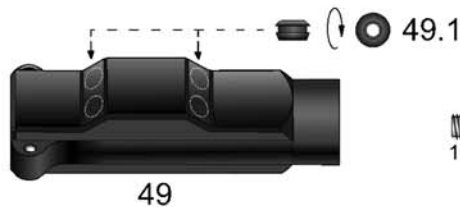
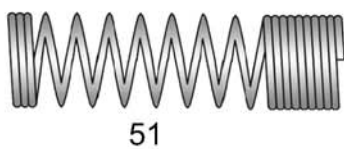
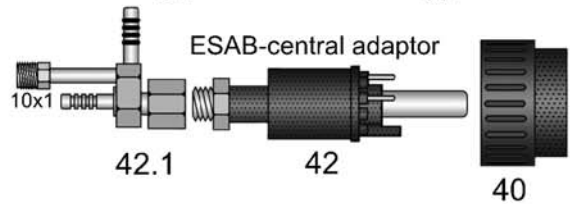
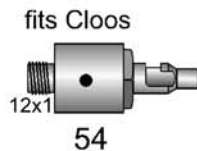
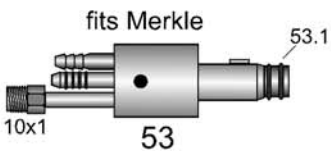
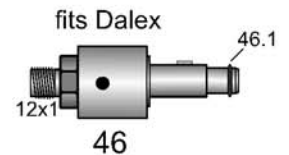
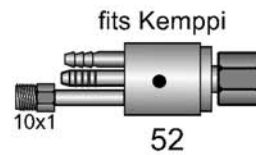
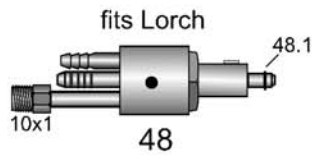
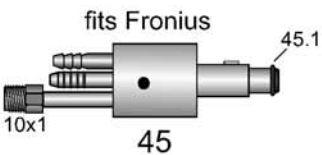
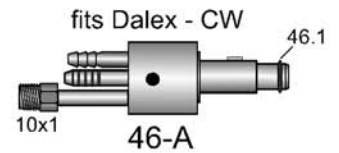
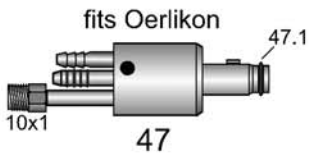
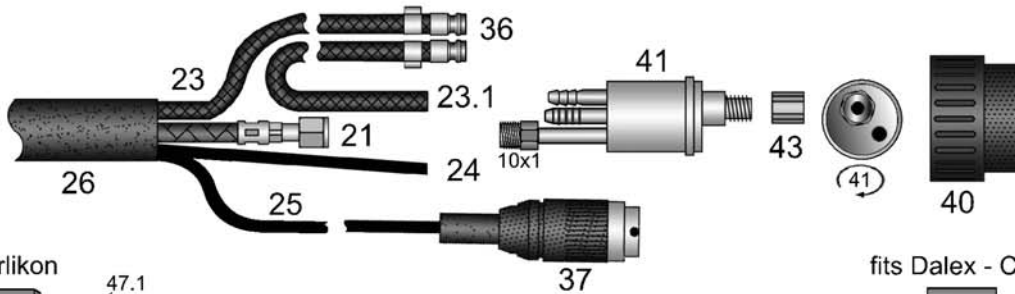

HSN 530



SR 18 - TW water-cooled spare parts

Equipment: **A** standard

B gas lens

D gas lens jumbo

E gas lens mini

F standard mini

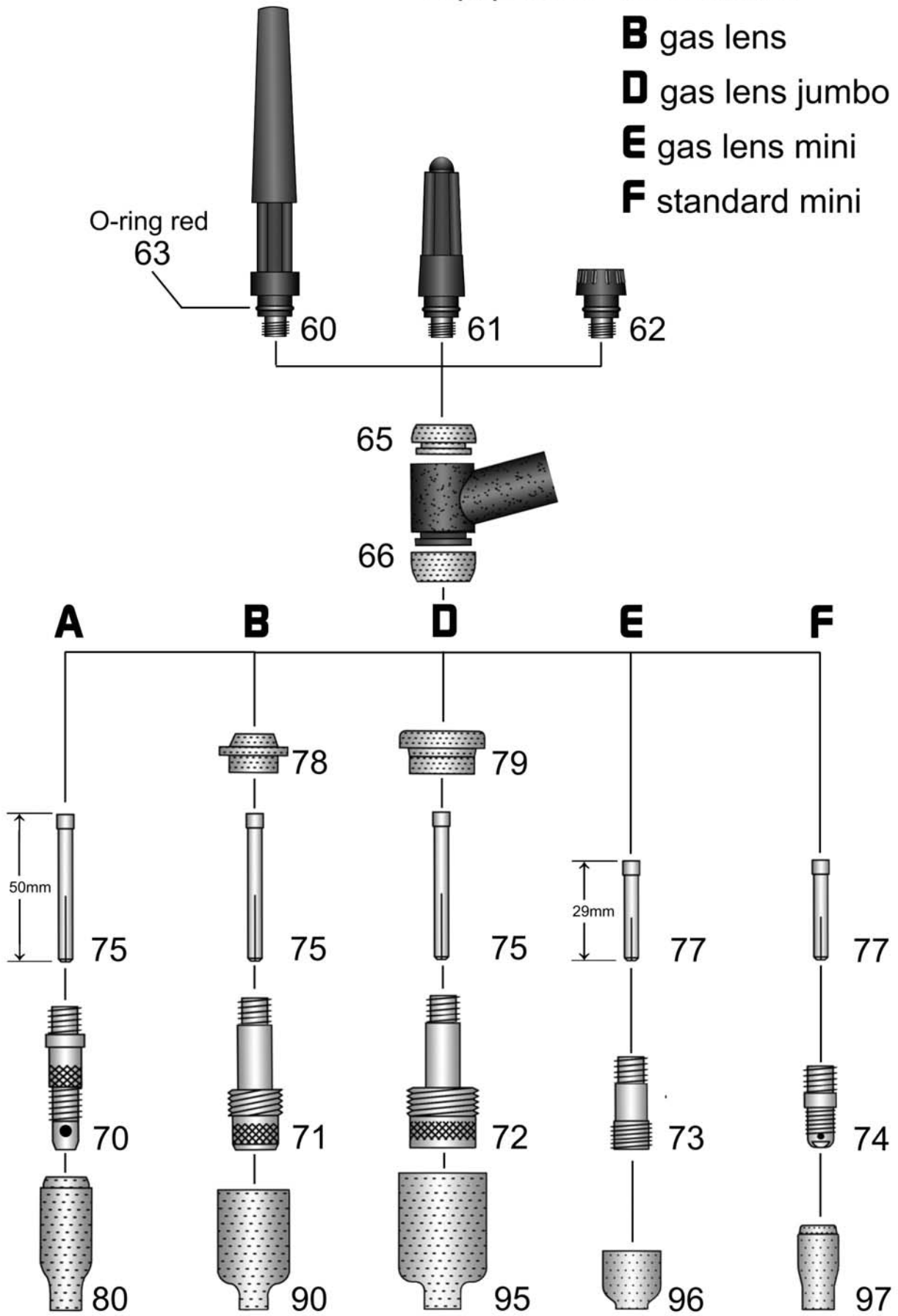

HSN 112

Welding-torch TIG water-cooled**320A at 100% duty cycle (DC) - 240A at 100% duty cycle (AC)****Art.-No.**

Torches with first meter leather hose. Prices without leather on request. Machine side separate connections with Tuchel plug.

In variation to the torches listed below, the torches can also be produced with other power/water cables (e.g. HT 180 silicone superflexible). This can also be combined with hoses in a lot of different qualities. Torches and cable assemblies can be produced in excess lengths. Please find the different options and surcharges in the attachment "Custom made products" appendix C. We produce torches for more than 40 different brands of machines with different connection systems.

18700401 Torch SR 18-TW / 4m spare cable assembly ST 80 PVC-NIT

18700801 Torch SR 18-TW / 8m spare cable assembly ST 80 PVC-NIT

The following torches are equipped with very flexible and heat resistant HT110 rubber fabric hoses.

1870040P Torch SR 18-TW-PLUS / 4m spare cable assembly HT 110

1870080P Torch SR 18-TW-PLUS / 8m spare cable assembly HT 110

TIG-spares cable assemblies in different qualities, machine side with separate connections and Tuchel plug, or, if ordered so, with the following connection systems:

wig92402 TIG-spares cable assembly water-cooled 4m - please state desired design!

wig92802 TIG-spares cable assembly water-cooled 8m - please state desired design!

The following surcharges for machine side connections are only to find prices quickly. Please use our catalogue "TIG machine side connections" to find a "T" number which identifies a machine side connection system completely.

29002102 Surcharge: machine side power/water plug SK35 bayonet connection AD13mm

29000201 Surcharge: machine side with EURO central adapter

29002109 Surcharge: machine side power/water plug fits Merkle with 2 O-rings

29002106 Surcharge: machine side power/water plug fits Fronius with 1 O-ring

29002101 Surcharge: machine side power/water plug fits Dalex with 1 O-ring

29002108 Surcharge: machine side power/water plug fits Oerlikon with 1 O-ring

29002104 Surcharge: machine side power/water plug fits Lorch SK35 + gas-nipple

29002105 Surcharge: machine side power/water plug fits Kemppi IT-G1/4"

29002110 Surcharge: machine side power/water plug fits Cloos

29000212 Surcharge: machine side fits ESAB central adapter, 4 pins installed at position 3,4,5,6

poti2901 Surcharge: 1 button with additional potentiometer

ud290001 Surcharge: 4 switches > up / down

Please note that there might be additional charges for special control line plugs. See appendix D.

1 18791001 Torch body SR 18-TW

6 18050002 Ignition insulating hose L75mm / ID39mm down to ID13mm

11.1 91914601 Forma TIG handle with screws, ball joint, without modular switch unit

11.2 91914602 Forma screw for handle

11.3 91914603 Forma hose bracket with ball joint ID21,5mm (also fits MG-handle)

11.4 91914611 Forma modular switch unit: 1 button with connecting adapter

11.5 91914621 Forma modular switch unit: 2 buttons with connecting adapter

11.6 91914631 Forma modular switch unit: 1 button + potentiometer (10k) with connecting adapter

11.7 91914641 Forma modular switch unit: 2 buttons + up/down (4 switches) with connecting adapter

11.8 91914651 Forma connecting adapter fits control line to modular switch unit

N.i. 91914661 Forma switch module safety nipple

Welding-torch TIG water-cooled**320A at 100% duty cycle (DC) - 240A at 100% duty cycle (AC)**

Art.-No.		
12.1	91914061	MG-handle with ball joint, push-button, 2 return springs, 2 microswitches and 4 cylindrical pins
13	91914421	MG-tapping screw
14	91915002	MG-push button
16	91914121	MG-microswitch
17	91914221	MG-return spring
18	91914321	MG-cylindrical pin
Please state the machine side connection for the following power/water cables.		
For 4m long torches:		
20	12942401	ST 80 PVC-NIT power/water cable 10mm ² 12/18/20-TW / 4m
20	12942404	HT 105 PVC-NIT power/water cable 10mm ² 12/18/20-TW / 4m
20	12942403	HT 110 rubber fabric hose power/water cable 10mm ² 12/18/20-TW / 4m
20	12942405	HT 130 TPE power/water cable 10mm ² 12/18/20-TW / 4m
20	12942408	HT 180 silicone super flexible power/water cable 10mm ² 12/18/20-TW / 4m
For 8m long torches:		
20	12942801	ST 80 PVC-NIT power/water cable 10mm ² 12/18/20-TW / 8m
20	12942804	HT 105 PVC-NIT power/water cable 10mm ² 12/18/20-TW / 8m
20	12942803	HT 110 Rubber fabric hose power/water cable 10mm ² 12/18/20-TW / 8m
20	12942805	HT 130 TPE power/water cable 10mm ² 12/18/20-TW / 8m
20	12942808	HT 180 silicone super flexible power/water cable 10mm ² 12/18/20-TW / 8m
The following power/water cables are produced with M10x1 inner thread at the machine side for EURO central adapters. (fits to all Holch connection systems with outer thread M10x1).		
For 4m long torches:		
21	12942411	ST 80 PVC-NIT power/water cable 10mm ² 12/18/20-TW / 4m
21	12942414	HT 105 PVC-NIT power/water cable 10mm ² 12/18/20-TW / 4m
21	12942413	HT 110 rubber fabric hose power/water cable 10mm ² 12/18/20-TW / 4m
21	12942415	HT 130 TPE power/water cable 10mm ² 12/18/20-TW / 4m
21	12942418	HT 180 silicone super flexible power/water cable 10mm ² 12/18/20-TW / 4m
For 8m long torches:		
21	12942811	ST 80 PVC-NIT power/water cable 10mm ² 12/18/20-TW / 8m
21	12942814	HT 105 PVC-NIT power/water cable 10mm ² 12/18/20-TW / 8m
21	12942813	HT 110 rubber fabric hose power/water cable 10mm ² 12/18/20-TW / 8m
21	12942815	HT 130 TPE power/water cable 10mm ² 12/18/20-TW / 8m
21	12942818	HT 180 silicone super flexible power/water cable 10mm ² 12/18/20-TW / 8m
Reel goods:		
Prices are per meter and only applicable for purchasing of complete rolls		
23	50150001	Meter ST 80 PVC-NIT fabric hose ID5,0-W1,5mm blue for water (100m)
23	51700002	Meter HT 110 rubber fabric hose ID5,0-W1,7mm blue for water (100m)
23.1	50151001	Meter ST 80 PVC-NIT fabric hose ID5,0-W1,5mm red for water (100m)
23.1	51700003	Meter HT 110 rubber fabric hose ID5,0-W1,7mm red for water (100m)
24	31000001	Meter ST 70 PVC hose ID3,0-W1,0mm black for gas (100m)
24	51700001	Meter HT 110 rubber fabric hose ID5,0-W1,7mm black for gas (100m)
24	31200001	Meter HT 130 PUR hose ID3-W1,2mm black for gas (100m)
N.i.	91902701	Meter control line 3x0,34mm ² shielded black (100m)
N.i.	91902711	Meter control line 3x0,5mm ² red (100m)
25	91902721	Meter control line 5x0,25mm ² grey (100m)
26	22150002	Meter neoprene protective hose ID22mm black (40m)

Welding-torch TIG water-cooled**320A at 100% duty cycle (DC) - 240A at 100% duty cycle (AC)**

Art.-No.		
N.i.	91915004	Leather protective hose ID22mm / 1 meter long
N.i.	91915007	Leather protective hose ID22mm / 1 meter long with ball joint and hose connector
N.i.	91915003	Hose connector leather protective hose / protection hose ID19,5mm
34	91901501	Coupling nut IT-G1/4"
N.i.	91901211	Hose connector 4mm fits coupling nut R1/4"
35	91901601	Coupling nut IT-G3/8"
N.i.	91901301	Hose connector 5mm fits Coupling nut R3/8"
36	91901001	Cooling liquid plug nipples EURO
N.i.	91901008	Closing cap blue fits cooling liquid plug nipples EURO
N.i.	91901009	Closing cap red fits cooling liquid plug nipples EURO
37	91904101	Plug 3-poles Tuchel with bayonet-catch
37	91904111	Plug 5-poles Tuchel with bayonet-catch
More control line plugs see appendix D		
40	91900701	Terminal nut insulated fits EURO central adapter
41	91900211	TIG central adapter EURO central adapter water cooled
42	91900301	TIG central adapter identical ESAB, 4 contact pins at position 3,4,5,6
42.1	91918571	TIG power/cooling liquid junction fits ESAB central adapter
42.3	91918312	TIG central adapter SK-35 bayonet connection AD13mm
43	91900901	Coupling nut IT-M10x1 (rounded edges) fits EURO central adapter
45	91918327	Power/water plug fits Fronius with 1 O-ring (OT-M10x1 / like EURO central adapter)
45.1	62190001	O-ring ID6,2-W1,9mm fits Fronius
46	9190417e	Power/water plug fits Dalex (1 O-ring) (OT-12x1)
46-A	9190418n	Power-/gasplug fits Dalex with waterdeviation to outside, CW-System with 1 O-ring
46.1	63240001	O-ring ID6,3-W2,4mm fits Dalex
47	9190423n	Power/water plug fits Oerlikon with 1 O-ring (OT-M10x1 / like EURO central adapter)
47.1	60717801	O-ring ID6,07-W1,78mm fits Oerlikon
48	9190420n	Power/water plug fits Lorch SK35 + gas-nipple (OT-10x1 / like EURO central adapter)
48.1	91900801	O-ring ID4-W1mm fits gas-nipple EURO central adapter
o.A	91900552	TIG cable support long (like MIG-MAG) with screws fits ESAB central adapter
N.i.	91900554	Attachment screw M4x8mm fits ESAB central adapter
49	91900557	TIG cable support short with screws (fits water-cooled)
N.i.	91920702	Screw M3x11,5mm for Ratio/Industry/RAUCH handle and cable support
N.i.	91920703	M3 mounting socket for Ratio/Industry/RAUCH handle and cable support
o.A.	91900602	Screw M4x6mm for TIG cable support short
49.1	91901012	Reduction-eyelet (rubber) from ID10,5mm to ID5mm fits TIG cable support short
N.i.	91921701	PUR hose ID8,5-W1,0mm 150mm long fits leading water hoses into cable support
50	91912801	Spring-socket EURO central adapter
51	91912601	Cable support spring fits EURO / ESAB central adapter
52	9190419n	Power/water plug fits Kemppi IT-G1/4" (AG-M10x1 / like EURO central adapter)
53	9190424n	Power/water plug fits Merkle with 2 O-rings (OT-M10x1 / like EURO central adapter)
53.1	81600001	O-ring ID8-W1,6mm fits Lorch/Merkle
54	9190415n	Powerplug fits Cloos (special-plug) (OT-12x1)
60	17191311	Holch back cap long (USA version with red O-ring) SR 17-18-26 57Y02

Welding-torch TIG water-cooled**320A at 100% duty cycle (DC) - 240A at 100% duty cycle (AC)**

Art.-No.		
61	17191322	Import back cap medium (USA version with red O-ring) SR 17-18-26 57Y03
62	17191301	Holch back cap short (USA version with red O-ring) SR 17-18-26 57Y04
63	17189001	O-ring red ID8-W2mm for back cap
65	17289001	PTFE-back-cap gasket ring SR 17-18-26 18-7
66	17289021	PTFE-isolator SR 17-18-26 18CG
70	17961002	Collet body 17-18-26-220 / 1,0 10N30
70	17961602	Collet body 17-18-26-220 / 1,6 10N31
70	17962402	Collet body 17-18-26-220 / 2,4 10N32
70	18963202	Collet body 17-18-26-220 / 3,2 10N28
70	18964002	Collet body 17-18-26-220 / 4,0 406488
71	17961011	Gas lens 17-18-26-220 / 1,0 45V24
71	17961611	Gas lens 17-18-26-220 / 1,6 45V25
71	17962411	Gas lens 17-18-26-220 / 2,4 45V26
71	18963211	Gas lens 17-18-26-220 / 3,2 45V27
71	18964011	Gas lens 17-18-26-220 / 4,0 45V28
72	17961021	Jumbo gas lens 17-18-26-220 / 1,0 45V0204
72	17961621	Jumbo gas lens 17-18-26-220 / 1,6 45V116
72	17962421	Jumbo gas lens 17-18-26-220 / 2,4 45V64
72	18963221	Jumbo gas lens 17-18-26-220 / 3,2 995795
72	18964021	Jumbo gas lens 17-18-26-220 / 4,0 45V63
73	17961031	Gas lens "Mini" SR 17-18-26 / 1,0 conversion kit
73	17961631	Gas lens "Mini" SR 17-18-26 / 1,6 conversion kit
73	17962431	Gas lens "Mini" SR 17-18-26 / 2,4 conversion kit
73	18963231	Gas lens "Mini" SR 17-18-26 / 3,2 conversion kit
74	18961003	Collet body "Mini" SR 17-18-26 1,0 conversion kit
74	18961603	Collet body "Mini" SR 17-18-26 1,6 conversion kit
74	18962403	Collet body "Mini" SR 17-18-26 2,4 conversion kit
74	18963203	Collet body "Mini" SR 17-18-26 / 1,0 - 3,2 17CB20 conversion kit
Brazen collets L-50mm		
suitable equipment line (A) standard collet body		
suitable equipment line (B) gas lens		
suitable equipment line (D) gas lens jumbo		
75	17105002	Collet L50mm SR 17-18-26 wp-18SC / 1,0 10N22
75	17165002	Collet L50mm SR 17-18-26 wp-18SC / 1,6 10N23
75	17245002	Collet L50mm SR 17-18-26 wp-18SC / 2,4 10N24
75	18325002	Collet L50mm SR 17-18-26 wp-18SC / 3,2 10N25
75	18405002	Collet L50mm SR 17-18-26 / 4,0 54N20
Copper-collets L-29mm		
suitable equipment line (F) standard collet body mini		
77	17103002	Collet L29mm SR 17-18-26 "Mini" 1,0 10N22S
77	17163002	Collet L29mm SR 17-18-26 "Mini" 1,6 10N23S
77	17243002	Collet L29mm SR 17-18-26 "Mini" 1,6 10N23S
77	18323002	Collet L29mm SR 17-18-26 "Mini" 3,2 10N25S
78	17089021	PTFE-Gas-lens insulator 17-18-26-220 54N01

Welding-torch TIG water-cooled**320A at 100% duty cycle (DC) - 240A at 100% duty cycle (AC)**

Art.-No.					
79	17089031	PTFE-Gas-lens insulator Jumbo	17-18-26-220	54N63	
Ceramic gas nozzles in different lengths suitable equipment line (A) standard collet body					
80	17930401	Ceramic gas nozzle L47mm	17-18-26-220 / Gr.4	10N50	(pu=10pieces)
80	17930501	Ceramic gas nozzle L47mm	17-18-26-220 / Gr.5	10N49	(pu=10pieces)
80	17930601	Ceramic gas nozzle L47mm	17-18-26-220 / Gr.6	10N48	(pu=10pieces)
80	17930701	Ceramic gas nozzle L47mm	17-18-26-220 / Gr.7	10N47	(pu=10pieces)
80	17930801	Ceramic gas nozzle L47mm	17-18-26-220 / Gr.8	10N46	(pu=10pieces)
80	17930101	Ceramic gas nozzle L47mm	17-18-26-220 / Gr.10	10N45	(pu=10pieces)
80	17930121	Ceramic gas nozzle L47mm	17-18-26-220 / Gr.12	10N44	(pu=10pieces)
N.i.	17930404	Ceramic gas nozzle L76mm	17-18-26-220 / Gr.4	10N50L	(pu=10pieces)
N.i.	17930504	Ceramic gas nozzle L76mm	17-18-26-220 / Gr.5	10N49L	(pu=10pieces)
N.i.	17930604	Ceramic gas nozzle L76mm	17-18-26-220 / Gr.6	10N48L	(pu=10pieces)
N.i.	17930704	Ceramic gas nozzle L76mm	17-18-26-220 / Gr.7	10N47L	(pu=10pieces)
Ceramic gas nozzles in different lengths suitable equipment line (B) gas lens					
90	22093041	Gas nozzle for gas lens L42mm / Gr.4	54N18		(pu=10pieces)
90	22093051	Gas nozzle for gas lens L42mm / Gr.5	54N17		(pu=10pieces)
90	22093061	Gas nozzle for gas lens L42mm / Gr.6	54N16		(pu=10pieces)
90	22093071	Gas nozzle for gas lens L42mm / Gr.7	54N15		(pu=10pieces)
90	22093081	Gas nozzle for gas lens L42mm / Gr.8	54N14		(pu=10pieces)
90	22093111	Gas nozzle for gas lens L42mm / Gr.11	54N19-11		(pu=10pieces)
90	22093121	Gas nozzle for gas lens L42mm / Gr.12	54N19		(pu=10pieces)
N.i.	22093054	Gas nozzle for gas lens L76mm / Gr.5	54N17L		(pu=10pieces)
N.i.	22093064	Gas nozzle for gas lens L76mm / Gr.6	54N16L		(pu=10pieces)
N.i.	22093074	Gas nozzle for gas lens L76mm / Gr.7	54N15L		(pu=10pieces)
N.i.	22093084	Gas nozzle for gas lens L76mm / Gr.8	54N14L		(pu=10pieces)
Ceramic gas nozzles jumbo in different lengths suitable equipment line (D) gas lens jumbo					
95	22093066	Jumbo gas nozzle L48mm / Gr.6	57N75		(pu=10pieces)
95	22093086	Jumbo gas nozzle L48mm / Gr.8	57N74		(pu=10pieces)
95	22093106	Jumbo gas nozzle L48mm / Gr.10	53N88		(pu=10pieces)
95	22093126	Jumbo gas nozzle L48mm / Gr.12	53N87		(pu=10pieces)
N.i.	22093067	Jumbo gas nozzle L73mm / Gr.6	57N75L		(pu=10pieces)
N.i.	22093087	Jumbo gas nozzle L73mm / Gr.8	57N74L		(pu=10pieces)
N.i.	22093107	Jumbo gas nozzle L73mm / Gr.10	53N88L		(pu=10pieces)
N.i.	22093127	Jumbo gas nozzle L73mm / Gr.12	53N87L		(pu=10pieces)
Ceramic gas nozzles L-20mm suitable equipment line (E) gas lens mini					
96	17930502	Ceramic gas nozzle L20mm SR 17-18-26 / Gr.5 fits gas lens "Mini"	53N59MS		(pu=10pieces)
96	17930602	Ceramic gas nozzle L20mm SR 17-18-26 / Gr.6 fits gas lens "Mini"	53N60MS		(pu=10pieces)
96	17930702	Ceramic gas nozzle L20mm SR 17-18-26 / Gr.7 fits gas lens "Mini"	53N61MS		(pu=10pieces)
Ceramic gas nozzles suitable equipment line (F) collet body standard mini					
97	20930401	Ceramic gas nozzle L30mm / Gr. 4	13N08		(pu=10pieces)

Welding-torch TIG water-cooled**320A at 100% duty cycle (DC) - 240A at 100% duty cycle (AC)**

Art.-No.					
97	20930501	Ceramic gas nozzle L30mm / Gr. 5	13N09	(pu=10pieces)	
97	20930601	Ceramic gas nozzle L30mm / Gr. 6	13N10	(pu=10pieces)	
97	20930701	Ceramic gas nozzle L30mm / Gr. 7	13N11	(pu=10pieces)	
97	20930801	Ceramic gas nozzle L30mm / Gr. 8	13N12	(pu=10pieces)	
97	20930101	Ceramic gas nozzle L30mm / Gr.10	13N13	(pu=10pieces)	
o.A	20930304	Ceramic gas nozzle L48mm / Gr. 3	796F70	(pu=10pieces)	
o.A	20930404	Ceramic gas nozzle L48mm / Gr. 4	796F71	(pu=10pieces)	
o.A	20930504	Ceramic gas nozzle L48mm / Gr. 5	796F72	(pu=10pieces)	
o.A	20930604	Ceramic gas nozzle L48mm / Gr. 6	796F73	(pu=10pieces)	
o.A	20930306	Ceramic gas nozzle L63mm / Gr. 3	796F74	(pu=10pieces)	
o.A	20930406	Ceramic gas nozzle L63mm / Gr. 4	796F75	(pu=10pieces)	
o.A	20930506	Ceramic gas nozzle L63mm / Gr. 5	796F76	(pu=10pieces)	
o.A	20930606	Ceramic gas nozzle L63mm / Gr. 6	796F77	(pu=10pieces)	
o.A	20930408	Ceramic gas nozzle L89mm / Gr. 4	796F79	(pu=10pieces)	

Top quality tungsten electrodes in 9 different qualities, see appendix A.

Torch wp-18SC-TW water-cooled



Holch Schweißbrenner GmbH
Bühlstraße 14
D-57080 Siegen

Phone: +49(0)271 387860-11
Telefax: +49(0)271 387860-29
E-Mail: info@holch-siegen.de
Web: www.holch-siegen.de

wp-18SC-TW water-cooled



400 Ampere at 100% duty cycle (DC) - 320 Ampere at 100% duty cycle (AC)

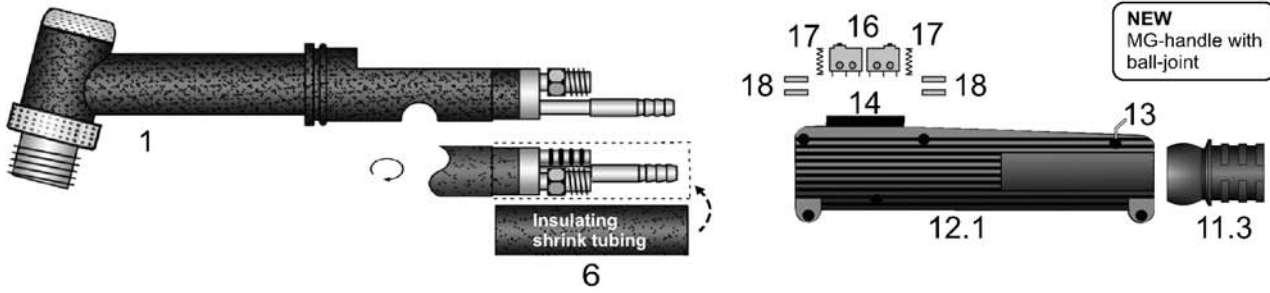

Forma WIG-handle with ball joint and different modular switch units

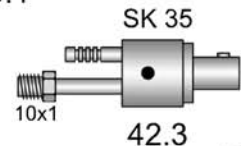
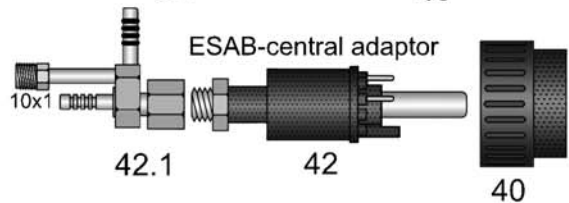
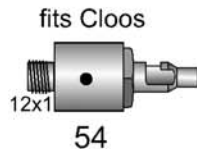
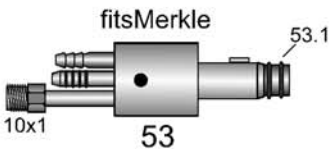
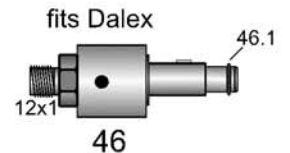
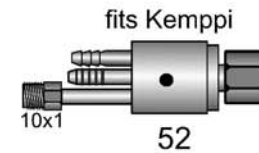
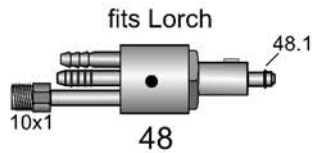
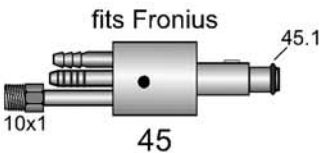
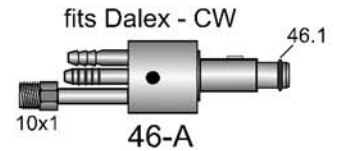
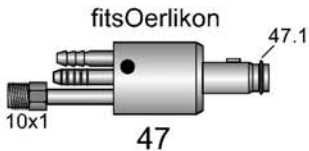
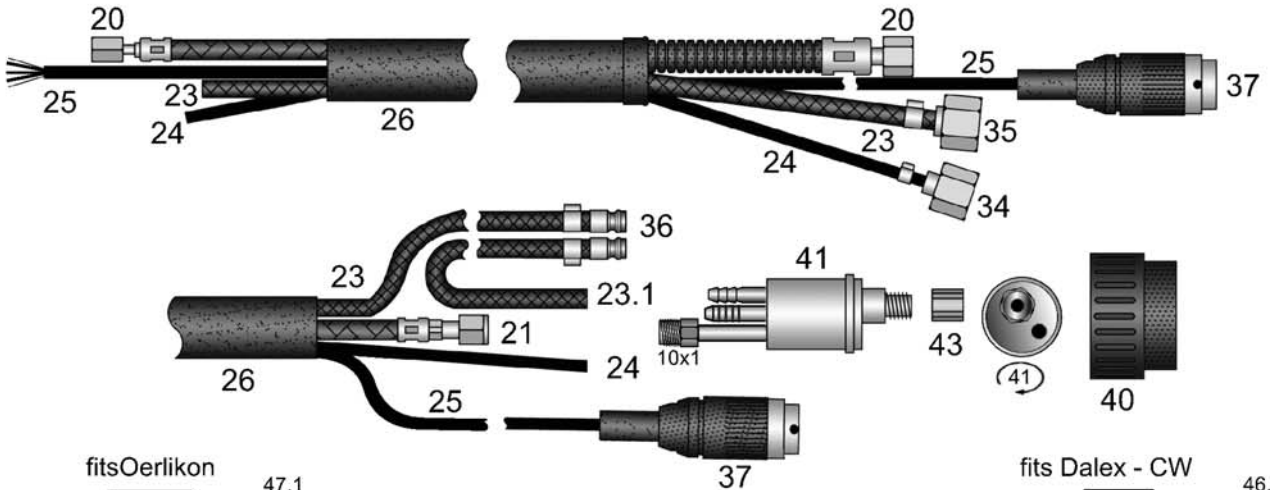

HSN 532

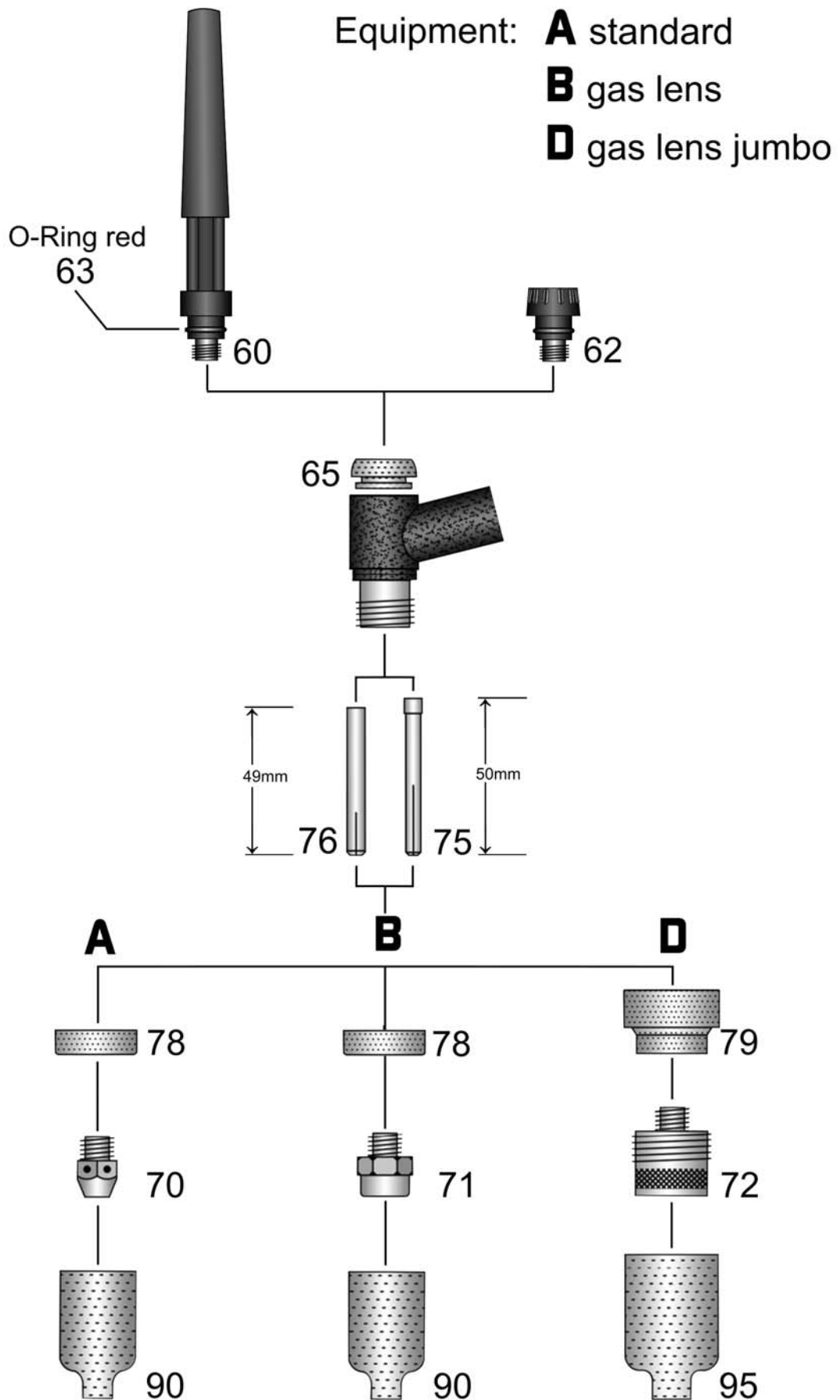

Welding-torch TIG water-cooled**400A at 100% duty cycle (DC) - 320A at 100% duty cycle (AC)****Art.-No.**

Torches with first meter leather hose. Prices without leather on request. Machine side separate connections with Tuchel plug.

In variation to the torches listed below, the torches can also be produced with other power/water cables (e.g. HT 180 silicone superflexible). This can also be combined with hoses in a lot of different qualities. Torches and cable assemblies can be produced in excess lengths. Please find the different options and surcharges in the attachment "Custom made products" appendix C. We produce torches for more than 40 different brands of machines with different connection systems.

18110401 Torch wp-18SC-TW / 4m spare cable assembly ST 80 PVC-NIT

18110801 Torch wp-18SC-TW / 8m spare cable assembly ST 80 PVC-NIT

The following torches are equipped with very flexible and heat resistant HT110 rubber fabric hoses.

1811040P Torch wp-18SC-TW / 4m spare cable assembly HT 110

1811080P Torch wp-18SC-TW / 8m spare cable assembly HT 110

TIG-spare cable assemblies in different qualities, machine side with separate connections and Tuchel plug, or, if ordered so, with the following connection systems:

wig92402 TIG-spare cable assembly water-cooled 4m - please state desired design!

wig92802 TIG-spare cable assembly water-cooled 8m - please state desired design!

The following surcharges for machine side connections are only to find prices quickly. Please use our catalogue "TIG machine side connections" to find a "T" number which identifies a machine side connection system completely.

29002102 Surcharge: machine side power/water plug SK35 bayonet connection AD13mm

29000201 Surcharge: machine side with EURO central adapter

29002109 Surcharge: machine side power/water plug fits Merkle with 2 O-rings

29002106 Surcharge: machine side power/water plug fits Fronius with 1 O-ring

29002101 Surcharge: machine side power/water plug fits Dalex with 1 O-ring

29002108 Surcharge: machine side power/water plug fits Oerlikon with 1 O-ring

29002104 Surcharge: machine side power/water plug fits Lorch SK35 + gas-nipple

29002105 Surcharge: machine side power/water plug fits Kemppi IT-G1/4"

29002110 Surcharge: machine side power/water plug fits Cloos

29000212 Surcharge: machine side fits ESAB central adapter, 4 pins installed at position 3,4,5,6

poti2901 Surcharge: 1 button with additional potentiometer

ud290001 Surcharge: 4 switches > up / down

Please note that there might be additional charges for special control line plugs. See appendix D.

1 18119101 Torch body wp-18SC-TW

6 18050002 Ignition insulating hose L75mm / ID39mm down to ID13mm

11.1 91914601 Forma TIG handle with screws, ball joint, without modular switch unit

11.2 91914602 Forma screw for handle

11.3 91914603 Forma hose bracket with ball joint ID21,5mm (also fits MG-handle)

11.4 91914611 Forma modular switch unit: 1 button with connecting adapter

11.5 91914621 Forma modular switch unit: 2 buttons with connecting adapter

11.6 91914631 Forma modular switch unit: 1 button + potentiometer (10k) with connecting adapter

11.7 91914641 Forma modular switch unit: 2 buttons + up/down (4 switches) with connecting adapter

11.8 91914651 Forma connecting adapter fits control line to modular switch unit

N.i. 91914661 Forma switch module safety nipple

Welding-torch TIG water-cooled**400A at 100% duty cycle (DC) - 320A at 100% duty cycle (AC)**

Art.-No.		
12.1	91914061	MG-handle with ball joint, push-button, 2 return springs, 2 microswitches and 4 cylindrical pins
13	91914421	MG-tapping screw
14	91915002	MG-push button
16	91914121	MG-microswitch
17	91914221	MG-return spring
18	91914321	MG-cylindrical pin
Please state the machine side connection for the following power/water cables.		
For 4m long torches:		
20	18943401	ST 80 PVC-NIT power/water cable 17,31mm ² wp-18SC-TW / 4m
20	18943404	HT 105 PVC-NIT power/water cable 17,31mm ² wp-18SC-TW / 4m
20	18943403	HT 110 rubber fabric hose power/water cable 17,31mm ² wp-18SC-TW / 4m
20	18943405	HT 130 TPE power/water cable 17,31mm ² wp-18SC-TW / 4m
20	18943408	HT 180 silicone super flexible power/water cable 17,31mm ² wp-18SC-TW / 4m
For 8m long torches:		
20	18943801	ST 80 PVC-NIT power/water cable 17,31mm ² wp-18SC-TW / 8m
20	18943804	HT 105 PVC-NIT power/water cable 17,31mm ² wp-18SC-TW / 8m
20	18943803	HT 110 rubber fabric hose power/water cable 17,31mm ² wp-18SC-TW / 8m
20	18943805	HT 130 TPE power/water cable 17,31mm ² wp-18SC-TW / 8m
20	18943808	HT 180 silicone super flexible power/water cable 17,31mm ² wp-18SC-TW / 8m
The following power/water cables are produced with M10x1 inner thread at the machine side for EURO central adapters. (fits to all Holch connection systems with outer thread M10x1).		
For 4m long torches:		
21	18943411	ST 80 PVC-NIT power/water cable 17,31mm ² wp-18SC-TW / 4m
21	18943414	HT 105 PVC-NIT power/water cable 17,31mm ² wp-18SC-TW / 4m
21	18943413	HT 110 rubber fabric hose power/water cable 17,31mm ² wp-18SC-TW / 4m
21	18943415	HT 130 TPE power/water cable 17,31mm ² wp-18SC-TW / 4m
21	18943418	HT 180 silicone super flexible power/water cable 17,31mm ² wp-18SC-TW / 4m
For 8m long torches:		
21	18943811	ST 80 PVC-NIT power/water cable 17,31mm ² wp-18SC-TW / 8m
21	18943814	HT 105 PVC-NIT power/water cable 17,31mm ² wp-18SC-TW / 8m
21	18943813	HT 110 rubber fabric hose power/water cable 17,31mm ² wp-18SC-TW / 8m
21	18943815	HT 130 TPE power/water cable 17,31mm ² wp-18SC-TW / 8m
21	18943818	HT 180 silicone super flexible power/water cable 17,31mm ² wp-18SC-TW / 8m
Reel goods:		
Prices are per meter and only applicable for purchasing of complete rolls		
23	50150001	Meter ST 80 PVC-NIT fabric hose ID5,0-W1,5mm blue for water (100m)
23	51700002	Meter HT 110 rubber fabric hose ID5,0-W1,7mm blue for water (100m)
23.1	50151001	Meter ST 80 PVC-NIT fabric hose ID5,0-W1,5mm red for water (100m)
23.1	51700003	Meter HT 110 rubber fabric hose ID5,0-W1,7mm red for water (100m)
24	31000001	Meter ST 70 PVC hose ID3,0-W1,0mm black for gas (100m)
24	51700001	Meter HT 110 rubber fabric hose ID5,0-W1,7mm black for gas (100m)
24	31200001	Meter HT 130 PUR hose ID3-W1,2mm black for gas (100m)
N.i.	91902701	Meter control line 3x0,34mm ² shielded black (100m)
N.i.	91902711	Meter control line 3x0,5mm ² red (100m)
25	91902721	Meter control line 5x0,25mm ² grey (100m)
26	22150002	Meter neoprene protective hose ID22mm black (40m)

Welding-torch TIG water-cooled**400A at 100% duty cycle (DC) - 320A at 100% duty cycle (AC)**

Art.-No.		
N.i.	91915004	Leather protective hose ID22mm / 1 meter long
N.i.	91915007	Leather protective hose ID22mm / 1 meter long with ball joint and hose connector
N.i.	91915003	Hose connector leather protective hose / protection hose ID19,5mm
34	91901501	Coupling nut IT-G1/4"
N.i.	91901211	Hose connector 4mm fits coupling nut R1/4"
35	91901601	Coupling nut IT-G3/8"
N.i.	91901301	Hose connector 5mm fits Coupling nut R3/8"
36	91901001	Cooling liquid plug nipples EURO
N.i.	91901008	Closing cap blue fits cooling liquid plug nipples EURO
N.i.	91901009	Closing cap red fits cooling liquid plug nipples EURO
37	91904101	Plug 3-poles Tuchel with bayonet-catch
37	91904111	Plug 5-poles Tuchel with bayonet-catch
More control line plugs see appendix D		
40	91900701	Terminal nut insulated fits EURO central adapter
41	91900211	TIG central adapter EURO central adapter water cooled
42	91900301	TIG central adapter identical ESAB, 4 contact pins at position 3,4,5,6
42.1	91918571	TIG power/cooling liquid junction fits ESAB central adapter
42.3	91918312	TIG central adapter SK-35 bayonet connection AD13mm
43	91900901	Coupling nut IT-M10x1 (rounded edges) fits EURO central adapter
45	91918327	Power/water plug fits Fronius with 1 O-ring (OT-M10x1 / like EURO central adapter)
45.1	62190001	O-ring ID6,2-W1,9mm fits Fronius
46	9190417e	Power/water plug fits Dalex (1 O-ring) (OT-12x1)
46-A	9190418n	Power-/gasplug fits Dalex with waterdeviation to outside, CW-System with 1 O-ring
46.1	63240001	O-ring ID6,3-W2,4mm fits Dalex
47	9190423n	Power/water plug fits Oerlikon with 1 O-ring (OT-M10x1 / like EURO central adapter)
47.1	60717801	O-ring ID6,07-W1,78mm fits Oerlikon
48	9190420n	Power/water plug fits Lorch SK35 + gas-nipple (OT-10x1 / like EURO central adapter)
48.1	91900801	O-ring ID4-W1mm fits gas-nipple EURO central adapter
o.A	91900552	TIG cable support long (like MIG-MAG) with screws fits ESAB central adapter
N.i.	91900554	Attachment screw M4x8mm fits ESAB central adapter
49	91900557	TIG cable support short with screws (fits water-cooled)
N.i.	91920702	Screw M3x11,5mm for Ratio/Industry/RAUCH handle and cable support
N.i.	91920703	M3 mounting socket for Ratio/Industry/RAUCH handle and cable support
o.A.	91900602	Screw M4x6mm for TIG cable support short
49.1	91901012	Reduction-eyelet (rubber) from ID10,5mm to ID5mm fits TIG cable support short
N.i.	91921701	PUR hose ID8,5-W1,0mm 150mm long fits leading water hoses into cable support
50	91912801	Spring-socket EURO central adapter
51	91912601	Cable support spring fits EURO / ESAB central adapter
52	9190419n	Power/water plug fits Kemppi IT-G1/4" (AG-M10x1 / like EURO central adapter)
53	9190424n	Power/water plug fits Merkle with 2 O-rings (OT-M10x1 / like EURO central adapter)
53.1	81600001	O-ring ID8-W1,6mm fits Lorch/Merkle
54	9190415n	Powerplug fits Cloos (special-plug) (OT-12x1)
60	17191311	Holch back cap long (USA version with red O-ring) SR 17-18-26 57Y02

Welding-torch TIG water-cooled**400A at 100% duty cycle (DC) - 320A at 100% duty cycle (AC)**

Art.-No.		
62	17191301	Holch back cap short (USA version with red O-ring) SR 17-18-26 57Y04
63	17189001	O-ring red ID8-W2mm for back cap
65	17289001	PTFE-back-cap gasket ring SR 17-18-26 18-7
70	18496001	Collet body for collets L49mm and L50mm up to 3,2 NCB-53
70	18496011	Collet body for collets L49mm from 1,6 up to 4,8 NCB-36
71	18496101	Gas lens wp-18SC / 1,0 18GL04
71	18496161	Gas lens wp-18SC / 1,6 18GL16
71	18496241	Gas lens wp-18SC / 2,4 18GL32
71	18496321	Gas lens wp-18SC / 3,2 18GL18
71	18496401	Gas lens wp-18SC / 4,0 18GL53
71	18496481	Gas lens wp-18SC / 4,8 18GL36
72	18496102	Jumbo gas lens wp-18SC / 1,0
72	18496162	Jumbo gas lens wp-18SC / 1,6 45V95
72	18496242	Jumbo gas lens wp-18SC / 2,4 45V96
72	18496322	Jumbo gas lens wp-18SC / 3,2 45V97
72	18496402	Jumbo gas lens wp-18SC / 4,0 45V98
72	18496482	Jumbo gas lens wp-18SC / 4,8 45V99
Brazen collets L-50mm suitable equipment line (A) standard collet body suitable equipment line (B) gas lens suitable equipment line (D) gas lens jumbo		
75	17105002	Collet L50mm SR 17-18-26 wp-18SC / 1,0 10N22
75	17165002	Collet L50mm SR 17-18-26 wp-18SC / 1,6 10N23
75	17245002	Collet L50mm SR 17-18-26 wp-18SC / 2,4 10N24
75	18325002	Collet L50mm SR 17-18-26 wp-18SC / 3,2 10N25
HL-Brazen collets L-49mm suitable equipment line (A) standard collet body suitable equipment line (B) gas lens suitable equipment line (D) gas lens jumbo		
76	18164901	HD-collet L49mm wp-18SC / 1,6
76	18244901	HD-collet L49mm wp-18SC / 2,4
76	18324901	HD-collet L49mm wp-18SC / 3,2 10N25HD
76	18404901	HD-collet L49mm wp-18SC / 4,0 54N20HD
76	18484901	HD-collet L49mm wp-18SC / 4,8 18C36
78	18489001	PTFE-Ceramic gas nozzle insulation wp-18SC 18NG
79	18489011	PTFE-Gas-lens insulator Jumbo wp-18SC 18NG-GL
Ceramic gas nozzles different lengths suitable equipment line (A) standard collet body suitable equipment line (B) gas lens		
90	22093041	Gas nozzle for gas lens L42mm / Gr.4 54N18 (pu=10pieces)
90	22093051	Gas nozzle for gas lens L42mm / Gr.5 54N17 (pu=10pieces)
90	22093061	Gas nozzle for gas lens L42mm / Gr.6 54N16 (pu=10pieces)
90	22093071	Gas nozzle for gas lens L42mm / Gr.7 54N15 (pu=10pieces)
90	22093081	Gas nozzle for gas lens L42mm / Gr.8 54N14 (pu=10pieces)
90	22093111	Gas nozzle for gas lens L42mm / Gr.11 54N19-11 (pu=10pieces)

Welding-torch TIG water-cooled**400A at 100% duty cycle (DC) - 320A at 100% duty cycle (AC)**

Art.-No.		
90	22093121	Gas nozzle for gas lens L42mm / Gr.12 54N19 (pu=10pieces)
N.i.	22093054	Gas nozzle for gas lens L76mm / Gr.5 54N17L (pu=10pieces)
N.i.	22093064	Gas nozzle for gas lens L76mm / Gr.6 54N16L (pu=10pieces)
N.i.	22093074	Gas nozzle for gas lens L76mm / Gr.7 54N15L (pu=10pieces)
N.i.	22093084	Gas nozzle for gas lens L76mm / Gr.8 54N14L (pu=10pieces)
Ceramic gas nozzles jumbo in different lengths suitable equipment line (D) gas lens jumbo		
95	22093066	Jumbo gas nozzle L48mm / Gr.6 57N75 (pu=10pieces)
95	22093086	Jumbo gas nozzle L48mm / Gr.8 57N74 (pu=10pieces)
95	22093106	Jumbo gas nozzle L48mm / Gr.10 53N88 (pu=10pieces)
95	22093126	Jumbo gas nozzle L48mm / Gr.12 53N87 (pu=10pieces)
N.i.	22093067	Jumbo gas nozzle L73mm / Gr.6 57N75L (pu=10pieces)
N.i.	22093087	Jumbo gas nozzle L73mm / Gr.8 57N74L (pu=10pieces)
N.i.	22093107	Jumbo gas nozzle L73mm / Gr.10 53N88L (pu=10pieces)
N.i.	22093127	Jumbo gas nozzle L73mm / Gr.12 53N87L (pu=10pieces)
Top quality tungsten electrodes in 9 different qualities, see appendix A.		

Torch 20-TW water-cooled



Holch Schweißbrenner GmbH
Bühlstraße 14
D-57080 Siegen

Phone: +49(0)271 387860-11
Telefax: +49(0)271 387860-29
E-Mail: info@holch-siegen.de
Web: www.holch-siegen.de



20-TW water-cooled

220 Ampere at 100% duty cycle (DC) - 200 Ampere at 100% duty cycle (AC)

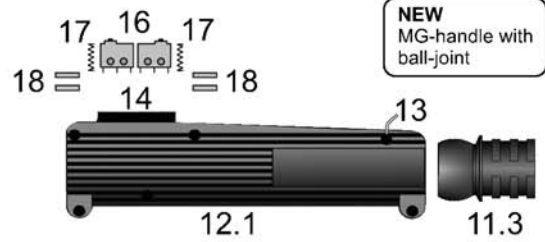
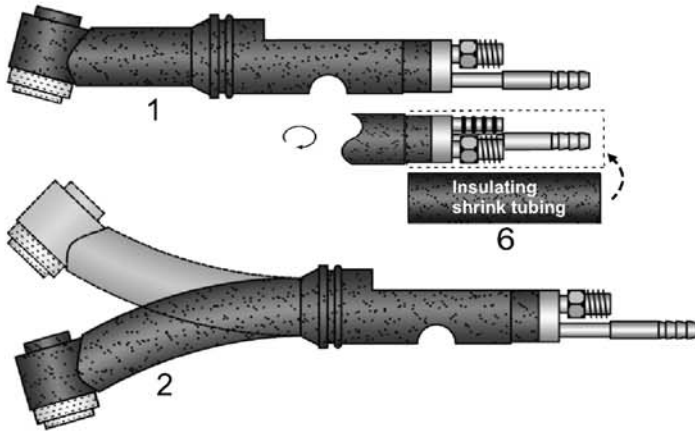

Forma WIG-handle with ball joint and different modular switch units

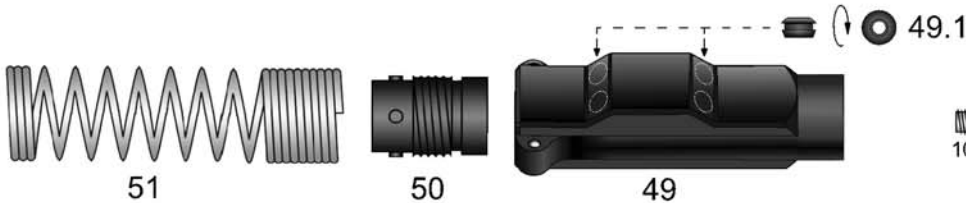
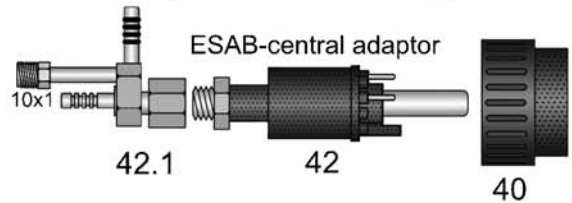
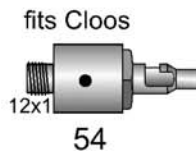
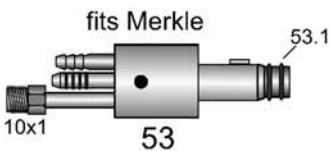
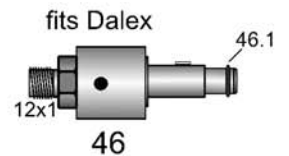
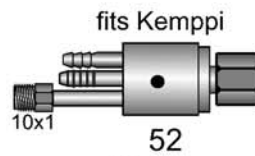
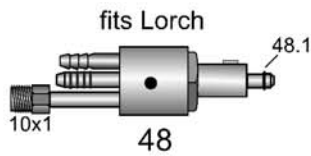
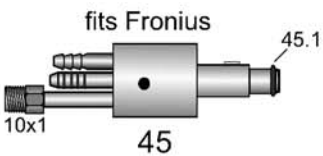
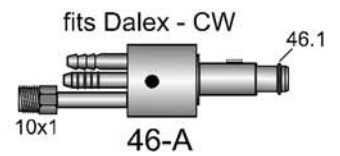
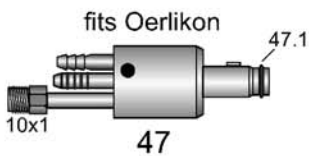
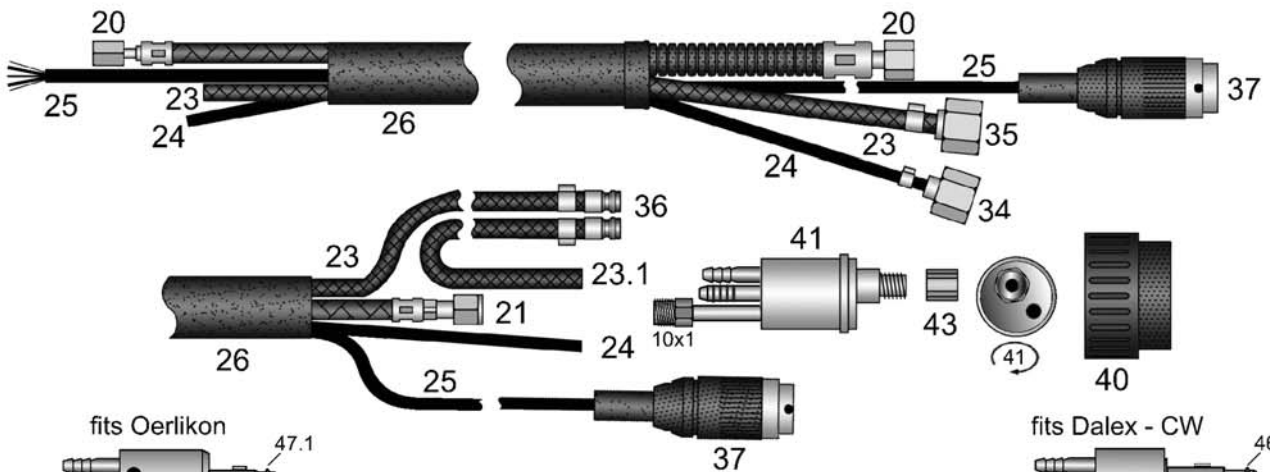

HSN 522



20 - TW water-cooled spare parts

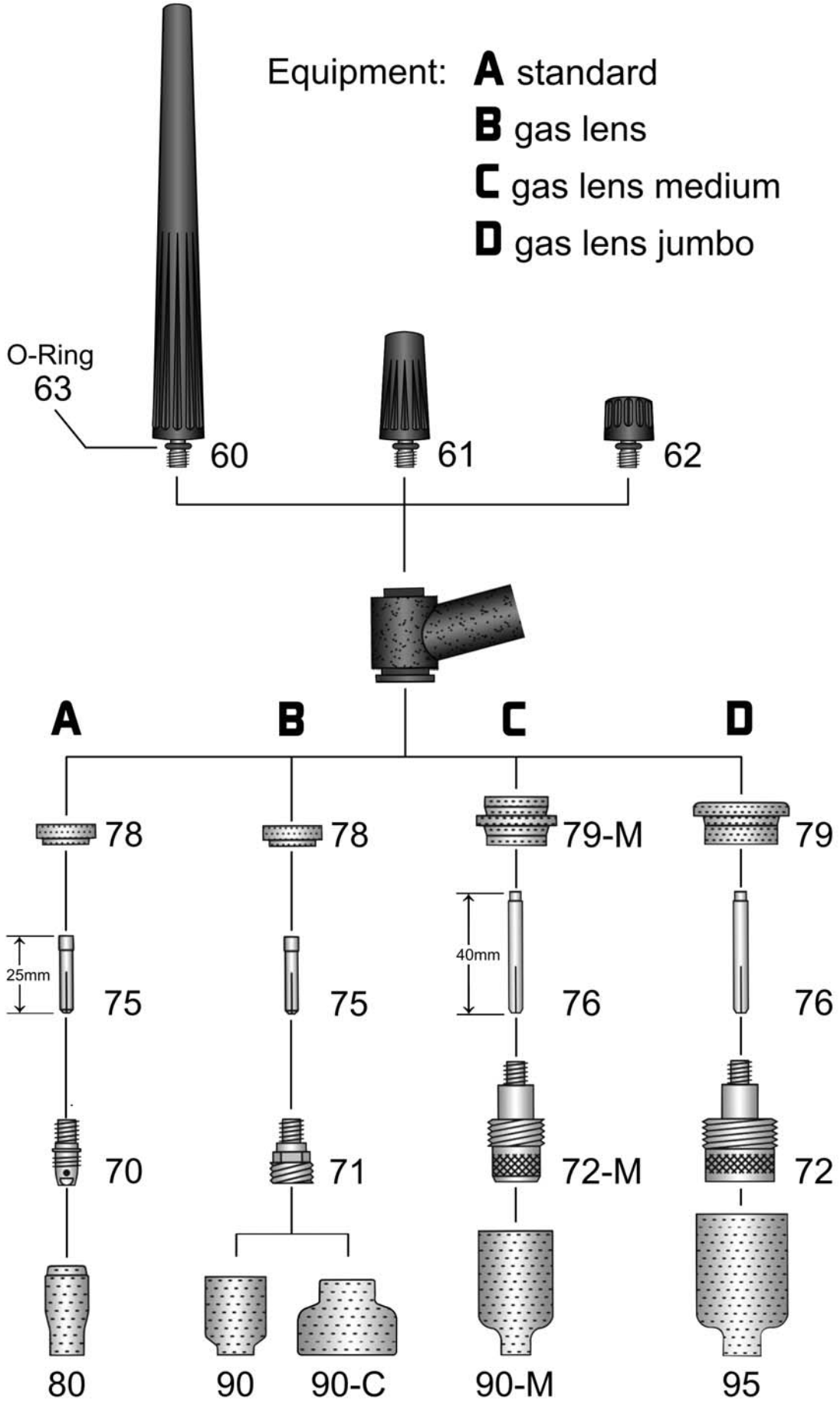

HSN 104-1

Welding-torch TIG water-cooled**220A at 100% duty cycle (DC) - 200A at 100% duty cycle (AC)****Art.-No.**

Torches with first meter leather hose. Prices without leather on request. Machine side separate connections with Tichel plug.

In variation to the torches listed below, the torches can also be produced with other power/water cables (e.g. HT 180 silicone superflexible). This can also be combined with hoses in a lot of different qualities. Torches and cable assemblies can be produced in excess lengths. Please find the different options and surcharges in the attachment "Custom made products" appendix C. We produce torches for more than 40 different brands of machines with different connection systems.

20700401	Torch 20-TW / 4m 6mm ² spare cable assembly ST 80 PVC-NIT
20700801	Torch 20-TW / 8m 6mm ² spare cable assembly ST 80 PVC-NIT
20710401	Torch 20-TW-SUPER / 4m 10mm ² spare cable assembly ST 80 PVC-NIT
20710801	Torch 20-TW-SUPER / 8m 10mm ² spare cable assembly ST 80 PVC-NIT

20800401	FLEX-torch 20F-TW / 4m 6mm ² neck flexible spare cable assembly ST 80 PVC-NIT
20800801	FLEX-torch 20F-TW / 8m 6mm ² neck flexible spare cable assembly ST 80 PVC-NIT
20810401	FLEX-torch 20F-TW-SUPER / 4m 10mm ² neck flexible spare cable assembly ST 80 PVC-NIT
20810801	FLEX-torch 20F-TW-SUPER / 8m 10mm ² neck flexible spare cable assembly ST 80 PVC-NIT

The following torches are equipped with very flexible and heat resistant HT110 rubber fabric hoses.

2070040P	Torch 20-TW-PLUS / 4m 6mm ² spare cable assembly HT 110
2070080P	Torch 20-TW-PLUS / 8m 6mm ² spare cable assembly HT 110
2071040P	Torch 20-TW-SUPER-PLUS / 4m 10mm ² spare cable assembly HT 110
2071080P	Torch 20-TW-SUPER-PLUS / 8m 10mm ² spare cable assembly HT 110

2080040P	FLEX-torch 20F-TW-PLUS / 4m 6mm ² neck flexible spare cable assembly HT 110
2080080P	FLEX-torch 20F-TW-PLUS / 8m 6mm ² neck flexible spare cable assembly HT 110
2081040P	FLEX-torch 20F-TW-SUPER-PLUS / 4m 10mm ² neck flexible spare cable assembly HT 110
2081080P	FLEX-torch 20F-TW-SUPER-PLUS / 8m 10mm ² neck flexible spare cable assembly HT 110

TIG-spare cable assemblies in different qualities, machine side with separate connections and Tichel plug, or, if ordered so, with the following connection systems:

wig92402	TIG-spare cable assembly water-cooled 4m - please state desired design!
wig92802	TIG-spare cable assembly water-cooled 8m - please state desired design!

The following surcharges for machine side connections are only to find prices quickly. Please use our catalogue "TIG machine side connections" to find a "T" number which identifies a machine side connection system completely.

29002102	Surcharge: machine side power/water plug SK35 bayonet connection AD13mm
29000201	Surcharge: machine side with EURO central adapter
29002109	Surcharge: machine side power/water plug fits Merkle with 2 O-rings
29002106	Surcharge: machine side power/water plug fits Fronius with 1 O-ring
29002101	Surcharge: machine side power/water plug fits Dalex with 1 O-ring
29002108	Surcharge: machine side power/water plug fits Oerlikon with 1 O-ring
29002104	Surcharge: machine side power/water plug fits Lorch SK35 + gas-nipple
29002105	Surcharge: machine side power/water plug fits Kemppi IT-G1/4"
29002110	Surcharge: machine side power/water plug fits Cloos
29000212	Surcharge: machine side fits ESAB central adapter, 4 pins installed at position 3,4,5,6
poti2901	Surcharge: 1 button with additional potentiometer
ud290001	Surcharge: 4 switches > up / down

Welding-torch TIG water-cooled**220A at 100% duty cycle (DC) - 200A at 100% duty cycle (AC)****Art.-No.**

Please note that there might be additional charges for special control line plugs. See appendix D.

1	20791001	Torch body 20-TW
2	20891001	Torch body 20F-TW neck flexible (FLEX)
6	18050002	Ignition insulating hose L75mm / ID39mm down to ID13mm
11.1	91914601	Forma TIG handle with screws, ball joint, without modular switch unit
11.2	91914602	Forma screw for handle
11.3	91914603	Forma hose bracket with ball joint ID21,5mm (also fits MG-handle)
11.4	91914611	Forma modular switch unit: 1 button with connecting adapter
11.5	91914621	Forma modular switch unit: 2 buttons with connecting adapter
11.6	91914631	Forma modular switch unit: 1 button + potentiometer (10k) with connecting adapter
11.7	91914641	Forma modular switch unit: 2 buttons + up/down (4 switches) with connecting adapter
11.8	91914651	Forma connecting adapter fits control line to modular switch unit
N.i.	91914661	Forma switch module safety nipple
12.1	91914061	MG-handle with ball joint, push-button, 2 return springs, 2 microswitches and 4 cylindrical pins
13	91914421	MG-tapping screw
14	91915002	MG-push button
16	91914121	MG-microswitch
17	91914221	MG-return spring
18	91914321	MG-cylindrical pin

Please state the machine side connection for the following power/water cables.

For 4m long torches:

20	20942401	ST 80 PVC-NIT power/water cable 6mm ² 20-TW / 4m
20	20942404	HT 105 PVC-NIT power/water cable 6mm ² 20-TW / 4m
20	20942403	HT 110 rubber fabric hose power/water cable 6mm ² 20-TW / 4m
20	20942405	HT 130 TPE power/water cable 6mm ² 20-TW / 4m
20	20942408	HT 180 silicone super flexible power/water cable 6mm ² 20-TW / 4m

20	12942401	ST 80 PVC-NIT power/water cable 10mm ² 12/18/20-TW / 4m
20	12942404	HT 105 PVC-NIT power/water cable 10mm ² 12/18/20-TW / 4m
20	12942403	HT 110 rubber fabric hose power/water cable 10mm ² 12/18/20-TW / 4m
20	12942405	HT 130 TPE power/water cable 10mm ² 12/18/20-TW / 4m
20	12942408	HT 180 silicone super flexible power/water cable 10mm ² 12/18/20-TW / 4m

For 8m long torches:

20	20942801	ST 80 PVC-NIT power/water cable 6mm ² 20-TW / 8m
20	20942804	HT 105 PVC-NIT power/water cable 6mm ² 20-TW / 8m
20	20942803	HT 110 rubber fabric hose power/water cable 6mm ² 20-TW / 8m
20	20942805	HT 130 TPE power/water cable 6mm ² 20-TW / 8m
20	20942808	HT 180 silicone super flexible power/water cable 6mm ² 20-TW / 8m

20	12942801	ST 80 PVC-NIT power/water cable 10mm ² 12/18/20-TW / 8m
20	12942804	HT 105 PVC-NIT power/water cable 10mm ² 12/18/20-TW / 8m
20	12942803	HT 110 Rubber fabric hose power/water cable 10mm ² 12/18/20-TW / 8m
20	12942805	HT 130 TPE power/water cable 10mm ² 12/18/20-TW / 8m
20	12942808	HT 180 silicone super flexible power/water cable 10mm ² 12/18/20-TW / 8m

Welding-torch TIG water-cooled**220A at 100% duty cycle (DC) - 200A at 100% duty cycle (AC)****Art.-No.**

The following power/water cables are produced with M10x1 inner thread at the machine side for EURO central adapters. (fits to all Holch connection systems with outer thread M10x1). For 4m long torches:

21	20942411	ST 80 PVC-NIT power/water cable 6mm ² 20-TW / 4m
21	20942414	HT 105 PVC-NIT power/water cable 6mm ² 20-TW / 4m
21	20942413	HT 110 rubber fabric hose power/water cable 6mm ² 20-TW / 4m
21	20942415	HT 130 TPE power/water cable 6mm ² 20-TW / 4m
21	20942418	HT 180 silicone super flexible power/water cable 6mm ² 20-TW / 4m
21	12942411	ST 80 PVC-NIT power/water cable 10mm ² 12/18/20-TW / 4m
21	12942414	HT 105 PVC-NIT power/water cable 10mm ² 12/18/20-TW / 4m
21	12942413	HT 110 rubber fabric hose power/water cable 10mm ² 12/18/20-TW / 4m
21	12942415	HT 130 TPE power/water cable 10mm ² 12/18/20-TW / 4m
21	12942418	HT 180 silicone super flexible power/water cable 10mm ² 12/18/20-TW / 4m

For 8m long torches:

21	20942811	ST 80 PVC-NIT power/water cable 6mm ² 20-TW / 8m
21	20942814	HT 105 PVC-NIT power/water cable 6mm ² 20-TW / 8m
21	20942813	HT 110 rubber fabric hose power/water cable 6mm ² 20-TW / 8m
21	20942815	HT 130 TPE power/water cable 6mm ² 20-TW / 8m
21	20942818	HT 180 silicone super flexible power/water cable 6mm ² 20-TW / 8m
21	12942811	ST 80 PVC-NIT power/water cable 10mm ² 12/18/20-TW / 8m
21	12942814	HT 105 PVC-NIT power/water cable 10mm ² 12/18/20-TW / 8m
21	12942813	HT 110 rubber fabric hose power/water cable 10mm ² 12/18/20-TW / 8m
21	12942815	HT 130 TPE power/water cable 10mm ² 12/18/20-TW / 8m
21	12942818	HT 180 silicone super flexible power/water cable 10mm ² 12/18/20-TW / 8m

Reel goods:**Prices are per meter and only applicable for purchasing of complete rolls**

23	50150001	Meter ST 80 PVC-NIT fabric hose ID5,0-W1,5mm blue for water (100m)
23	51700002	Meter HT 110 rubber fabric hose ID5,0-W1,7mm blue for water (100m)
23.1	50151001	Meter ST 80 PVC-NIT fabric hose ID5,0-W1,5mm red for water (100m)
23.1	51700003	Meter HT 110 rubber fabric hose ID5,0-W1,7mm red for water (100m)
24	31000001	Meter ST 70 PVC hose ID3,0-W1,0mm black for gas (100m)
24	51700001	Meter HT 110 rubber fabric hose ID5,0-W1,7mm black for gas (100m)
24	31200001	Meter HT 130 PUR hose ID3-W1,2mm black for gas (100m)

N.i.	91902701	Meter control line 3x0,34mm ² shielded black (100m)
N.i.	91902711	Meter control line 3x0,5mm ² red (100m)
25	91902721	Meter control line 5x0,25mm ² grey (100m)
26	20150002	Meter neoprene protective hose ID20mm black (40m)
26	22150002	Meter neoprene protective hose ID22mm black (40m)

N.i.	91915004	Leather protective hose ID22mm / 1 meter long
N.i.	91915007	Leather protective hose ID22mm / 1 meter long with ball joint and hose connector
N.i.	91915003	Hose connector leather protective hose / protection hose ID19,5mm

34	91901501	Coupling nut IT-G1/4"
N.i.	91901211	Hose connector 4mm fits coupling nut R1/4"
35	91901601	Coupling nut IT-G3/8"
N.i.	91901301	Hose connector 5mm fits Coupling nut R3/8"

Welding-torch TIG water-cooled**220A at 100% duty cycle (DC) - 200A at 100% duty cycle (AC)**

Art.-No.		
36	91901001	Cooling liquid plug nipples EURO
N.i.	91901008	Closing cap blue fits cooling liquid plug nipples EURO
N.i.	91901009	Closing cap red fits cooling liquid plug nipples EURO
37	91904101	Plug 3-poles Tuchel with bayonet-catch
37	91904111	Plug 5-poles Tuchel with bayonet-catch
More control line plugs see appendix D		
40	91900701	Terminal nut insulated fits EURO central adapter
41	91900211	TIG central adapter EURO central adapter water cooled
42	91900301	TIG central adapter identical ESAB, 4 contact pins at position 3,4,5,6
42.1	91918571	TIG power/cooling liquid junction fits ESAB central adapter
42.3	91918312	TIG central adapter SK-35 bayonet connection AD13mm
43	91900901	Coupling nut IT-M10x1 (rounded edges) fits EURO central adapter
45	91918327	Power/water plug fits Fronius with 1 O-ring (OT-M10x1 / like EURO central adapter)
45.1	62190001	O-ring ID6,2-W1,9mm fits Fronius
46	9190417e	Power/water plug fits Dalex (1 O-ring) (OT-12x1)
46-A	9190418n	Power-/gasplug fits Dalex with waterdeviation to outside, CW-System with 1 O-ring
46.1	63240001	O-ring ID6,3-W2,4mm fits Dalex
47	9190423n	Power/water plug fits Oerlikon with 1 O-ring (OT-M10x1 / like EURO central adapter)
47.1	60717801	O-ring ID6,07-W1,78mm fits Oerlikon
48	9190420n	Power/water plug fits Lorch SK35 + gas-nipple (OT-10x1 / like EURO central adapter)
48.1	91900801	O-ring ID4-W1mm fits gas-nipple EURO central adapter
o.A	91900552	TIG cable support long (like MIG-MAG) with screws fits ESAB central adapter
N.i.	91900554	Attachment screw M4x8mm fits ESAB central adapter
49	91900557	TIG cable support short with screws (fits water-cooled)
N.i.	91920702	Screw M3x11,5mm for Ratio/Industry/RAUCH handle and cable support
N.i.	91920703	M3 mounting socket for Ratio/Industry/RAUCH handle and cable support
o.A.	91900602	Screw M4x6mm for TIG cable support short
49.1	91901012	Reduction-eyelet (rubber) from ID10,5mm to ID5mm fits TIG cable support short
N.i.	91921701	PUR hose ID8,5-W1,0mm 150mm long fits leading water hoses into cable support
50	91912801	Spring-socket EURO central adapter
51	91912601	Cable support spring fits EURO / ESAB central adapter
52	9190419n	Power/water plug fits Kemppi IT-G1/4" (AG-M10x1 / like EURO central adapter)
53	9190424n	Power/water plug fits Merkle with 2 O-rings (OT-M10x1 / like EURO central adapter)
53.1	81600001	O-ring ID8-W1,6mm fits Lorch/Merkle
54	9190415n	Powerplug fits Cloos (special-plug) (OT-12x1)
60	20091321	Holch back cap long 9-20 41V24/41V24-D
61	20091311	Holch back cap medium 9-20 41V35/41V35-D
62	20091301	Holch back cap short 9-20 41V33/41V33-D
63	20089001	O-ring ID4,6-W2mm for back cap
70	20961002	Collet body 9-20 / 1,0 13N26
70	20961602	Collet body 9-20 / 1,6 13N27
70	20962402	Collet body 9-20 / 2,4 13N28
70	20963202	Collet body 9-20 / 3,2 13N29
71	20961011	Gas lens 9-20 / 1,0 45V42

Welding-torch TIG water-cooled**220A at 100% duty cycle (DC) - 200A at 100% duty cycle (AC)**

Art.-No.		
71	20961611	Gas lens 9-20 / 1,6 45V43
71	20962411	Gas lens 9-20 / 2,4 45V44
71	20963211	Gas lens 9-20 / 3,2 45V45
72-M	20961031	Gas lens medium 9-20 / 1,0
72-M	20961631	Gas lens medium 9-20 / 1,6
72-M	20962431	Gas lens medium 9-20 / 2,4
72-M	20963231	Gas lens medium 9-20 / 3,2
72	20961021	Jumbo gas lens 9-20 / 1,0 45V0204S
72	20961621	Jumbo gas lens 9-20 / 1,6 45V116S
72	20962421	Jumbo gas lens 9-20 / 2,4 45V64S
72	20963221	Jumbo gas lens 9-20 / 3,2 995795S
Brazen collets L-25mm		
suitable equipment line (A) standard collet body		
suitable equipment line (B) gas lens		
75	20102502	Collet L25mm 9-20 / 1,0 13N21
75	20162502	Collet L25mm 9-20 / 1,6 13N22
75	20242502	Collet L25mm 9-20 / 2,4 13N23
75	20322502	Collet L25mm 9-20 / 3,2 13N24
Brazen collets L-40mm		
suitable equipment line (C) gas lens midsize		
suitable equipment line (D) gas lens jumbo		
76	20104011	Collet L40mm 9-20 / 1,0 13N21L
76	20164011	Collet L40mm 9-20 / 1,6 13N22L
76	20244011	Collet L40mm 9-20 / 2,4 13N23L
76	20324011	Collet L40mm 9-20 / 3,2 13N24L
78	20089011	PTFE-isolator gasket 9-20
79-M	20089031	PTFE-gas lens isolator medium size 9-20
79	20089021	PTFE-gas lens isolator Jumbo 9-20 54N63-20
Ceramic gas nozzles in different lengths		
suitable equipment line (A) standard collet body		
80	20930401	Ceramic gas nozzle L30mm / Gr. 4 13N08 (pu=10pieces)
80	20930501	Ceramic gas nozzle L30mm / Gr. 5 13N09 (pu=10pieces)
80	20930601	Ceramic gas nozzle L30mm / Gr. 6 13N10 (pu=10pieces)
80	20930701	Ceramic gas nozzle L30mm / Gr. 7 13N11 (pu=10pieces)
80	20930801	Ceramic gas nozzle L30mm / Gr. 8 13N12 (pu=10pieces)
80	20930101	Ceramic gas nozzle L30mm / Gr.10 13N13 (pu=10pieces)
N.i.	20930304	Ceramic gas nozzle L48mm / Gr. 3 796F70 (pu=10pieces)
N.i.	20930404	Ceramic gas nozzle L48mm / Gr. 4 796F71 (pu=10pieces)
N.i.	20930504	Ceramic gas nozzle L48mm / Gr. 5 796F72 (pu=10pieces)
o.A	20930604	Ceramic gas nozzle L48mm / Gr. 6 796F73 (pu=10pieces)
N.i.	20930306	Ceramic gas nozzle L63mm / Gr. 3 796F74 (pu=10pieces)
N.i.	20930406	Ceramic gas nozzle L63mm / Gr. 4 796F75 (pu=10pieces)
N.i.	20930506	Ceramic gas nozzle L63mm / Gr. 5 796F76 (pu=10pieces)
N.i.	20930606	Ceramic gas nozzle L63mm / Gr. 6 796F77 (pu=10pieces)

Welding-torch TIG water-cooled**220A at 100% duty cycle (DC) - 200A at 100% duty cycle (AC)****Art.-No.**

N.i.	20930408	Ceramic gas nozzle L89mm / Gr. 4 796F79 (pu=10pieces)
Ceramic gas nozzles in different lengths suitable equipment line (B) gas lens		
90	20931401	Ceramic gas nozzle for gas lens L25,5mm 9-20 / Gr.4 53N58 (pu=10pieces)
90	20931501	Ceramic gas nozzle for gas lens L25,5mm 9-20 / Gr.5 53N59 (pu=10pieces)
90	20931601	Ceramic gas nozzle for gas lens L25,5mm 9-20 / Gr.6 53N60 (pu=10pieces)
90	20931701	Ceramic gas nozzle for gas lens L25,5mm 9-20 / Gr.7 53N61 (pu=10pieces)
90	20931801	Ceramic gas nozzle for gas lens L25,5mm 9-20 / Gr.8 53N61-S (pu=10pieces)
N.i.	20931404	Ceramic gas nozzle for gas lens L35mm 9-20 / Gr.4 53N58L (pu=10pieces)
N.i.	20931504	Ceramic gas nozzle for gas lens L35mm 9-20 / Gr.5 53N59L (pu=10pieces)
N.i.	20931604	Ceramic gas nozzle for gas lens L35mm 9-20 / Gr.6 53N60L (pu=10pieces)
N.i.	20931704	Ceramic gas nozzle for gas lens L35mm 9-20 / Gr.7 53N61L (pu=10pieces)
N.i.	20931406	Ceramic gas nozzle for gas lens L72mm 9-20 / Gr.4 53N58XL (pu=10pieces)
N.i.	20931506	Ceramic gas nozzle for gas lens L72mm 9-20 / Gr.5 53N59XL (pu=10pieces)
N.i.	20931606	Ceramic gas nozzle for gas lens L72mm 9-20 / Gr.6 53N60XL (pu=10pieces)
N.i.	20931706	Ceramic gas nozzle for gas lens L72mm 9-20 / Gr.7 53N61XL (pu=10pieces)
N.i.	20931806	Ceramic gas nozzle for gas lens L72mm 9-20 / Gr.8 53N61XL (pu=10pieces)
90-C	20930006	Ceramic nozzle for gas lens Kir Royal 9-20 / fits tungsten electrodes up to 2,4mm
90-C	20930016	Ceramic nozzle for gas lens Kir Royal 9-20 / fits tungsten electrode 3,2mm
Ceramic gas nozzles in different lengths suitable equipment line (C) midsize gas lens		
90-M	22093041	Gas nozzle for gas lens L42mm / Gr.4 54N18 (pu=10pieces)
90-M	22093051	Gas nozzle for gas lens L42mm / Gr.5 54N17 (pu=10pieces)
90-M	22093061	Gas nozzle for gas lens L42mm / Gr.6 54N16 (pu=10pieces)
90-M	22093071	Gas nozzle for gas lens L42mm / Gr.7 54N15 (pu=10pieces)
90-M	22093081	Gas nozzle for gas lens L42mm / Gr.8 54N14 (pu=10pieces)
90-M	22093111	Gas nozzle for gas lens L42mm / Gr.11 54N19-11 (pu=10pieces)
90-M	22093121	Gas nozzle for gas lens L42mm / Gr.12 54N19 (pu=10pieces)
N.i.	22093054	Gas nozzle for gas lens L76mm / Gr.5 54N17L (pu=10pieces)
N.i.	22093064	Gas nozzle for gas lens L76mm / Gr.6 54N16L (pu=10pieces)
N.i.	22093074	Gas nozzle for gas lens L76mm / Gr.7 54N15L (pu=10pieces)
N.i.	22093084	Gas nozzle for gas lens L76mm / Gr.8 54N14L (pu=10pieces)
Ceramic gas nozzles jumbo in different lengths suitable equipment line (D) gas lens jumbo		
95	22093066	Jumbo gas nozzle L48mm / Gr.6 57N75 (pu=10pieces)
95	22093086	Jumbo gas nozzle L48mm / Gr.8 57N74 (pu=10pieces)
95	22093106	Jumbo gas nozzle L48mm / Gr.10 53N88 (pu=10pieces)
95	22093126	Jumbo gas nozzle L48mm / Gr.12 53N87 (pu=10pieces)
N.i.	22093067	Jumbo gas nozzle L73mm / Gr.6 57N75L (pu=10pieces)
N.i.	22093087	Jumbo gas nozzle L73mm / Gr.8 57N74L (pu=10pieces)
N.i.	22093107	Jumbo gas nozzle L73mm / Gr.10 53N88L (pu=10pieces)
N.i.	22093127	Jumbo gas nozzle L73mm / Gr.12 53N87L (pu=10pieces)

Top quality tungsten electrodes in 9 different qualities, see appendix A.

Torch AUT 210-S gas-cooled



Holch Schweißbrenner GmbH
Bühlstraße 14
D-57080 Siegen

Phone: +49(0)271 387860-11
Telefax: +49(0)271 387860-29
E-Mail: info@holch-siegen.de
Web: www.holch-siegen.de



AUT 210-S gas-cooled

240 Ampere at 100% duty cycle (DC) - 200 Ampere at 100% duty cycle (AC)

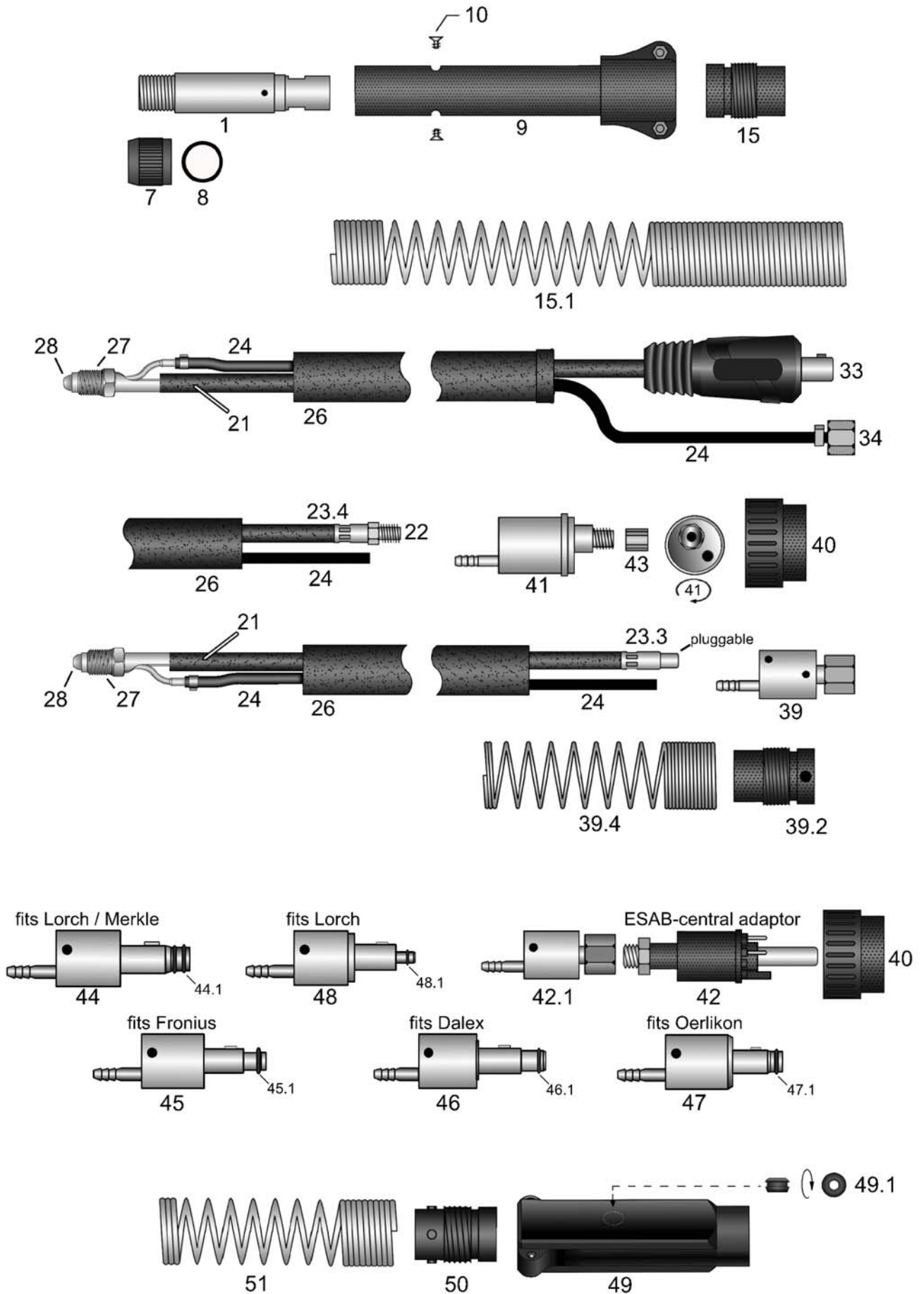

HSN 526



Equipment: **gas lens**

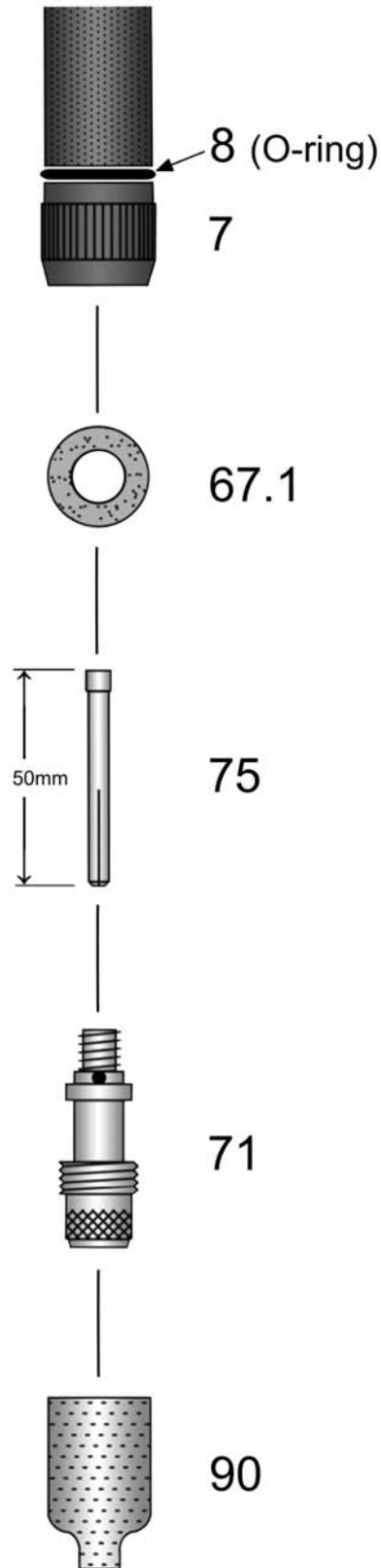

Welding-torch TIG gas-cooled**240A at 100% duty cycle (DC) - 200A at 100% duty cycle (AC)****Art.-No.****Torches without leatherhose. Machine side separate connections.****Torches and cable assemblies can be produced in excess lengths. Please find the different options and surcharges in the attachment "Custom made products" appendix C. We produce torches for more than 40 different brands of machines with different connection systems.**21000401 AUTomatic-torch 210-S / 4m 35mm²21000801 AUTomatic-torch 210-S / 8m 35mm²**TIG-spare cable assemblies in different qualities, machine side with separate connections and Tuchel plug, or, if ordered so, with the following connection systems:**

wig92401 TIG-spare cable assembly gas-cooled 4m - please state desired design!

wig92801 TIG-spare cable assembly gas-cooled 8m - please state desired design!

The following surcharges for machine side connections are only to find prices quickly. Please use our catalogue "TIG machine side connections" to find a "T"number which identifies a machine side connection system completely.

29000101 Surcharge: machine side with EURO central adapter

29002005 Surcharge: machine side power/gas plug fits Lorch/Merkle with 2 O-rings

29002004 Surcharge: machine side power/gas plug fits Fronius with 1 O-ring

29002006 Surcharge: machine side power/gas plug fits Dalex with 1 O-ring

29002107 Surcharge: machine side power/gas plug fits Oerlikon with 1 O-ring

29002002 Surcharge: machine side power/gas plug fits Lorch SK35 + gas-nipple

29000112 Surcharge: machine side fits ESAB central adapter, 4 pins installed at position 3,4,5,6

1 21091001 AUTomatic-torch body

7 21089011 Fabric base laminated socket

8 21089001 O-ring ID19-W2,4

9 21088003 Fabric base laminated handling tube AD27mm

10 21088101 Attachment screw plastic M4x6mm

15 91918541 TIG spring socket small power gas junction (pgj)

15.1 91912511 AUT cable support spring (long design)

20 26940403 Power cable 35mm² SR 26 / 4m fits power/gas plugs + power gas junction (pgj)20 26940803 Power cable 35mm² SR 26 / 8m fits power/gas plugs + power gas junction (pgj)21 26940402 Power cable 35mm² SR 26 / 4m with SK25 or SK-35 <--- please state!21 26940802 Power cable 35mm² SR 26 / 8m with SK25 or SK-35 <--- please state!22 26940404 Power cable 35mm² SR 26 / 4m EURO fits central adapter (OT-M10x1)22 26940804 Power cable 35mm² SR 26 / 8m EURO fits central adapter (OT-M10x1)23.3 22089057 TIG-Power cable connector plugable ID8,2mm fits 35mm²23.4 22089054 TIG-Power cable connector OT-M10x1 ID8,2mm fits 35mm²**Reel goods:****Prices are per meter and only applicable for purchasing of complete rolls**

24 41500001 Meter ST 70 PVC hose ID4,0-W1,5mm black for gas (100m)

26 22150002 Meter neoprene protective hose ID22mm black (40m)

27 91907601 Power cable connector separate lines OT-5/8"UNF-right-hand thread

Welding-torch TIG gas-cooled**240A at 100% duty cycle (DC) - 200A at 100% duty cycle (AC)**

Art.-No.		
28	91907612	Hose connector L105mm SR 26 pistol side
33	91918201	Powercable-plug SK-25 bayonet connection AD8mm
33	91918301	Powercable-plug SK-35 bayonet connection AD13mm
34	91901501	Coupling nut IT-G1/4"
N.i.	91901211	Hose connector 4mm fits coupling nut R1/4"
39	91918521	TIG power gas junction (pgj) with connection: IT-G1/8"
39	91918522	TIG power gas junction (pgj) with connection: IT-G1/4"
39	91918523	TIG power gas junction (pgj) with connection: IT-G3/8"
N.i.	91918551	Attachment screw (plastic) M5x12mm for power gas junction (pgj)
N.i.	91918552	3 grommets for attachment screws M5x12mm power gas junction (pgj)
N.i.	91918542	Section of insulating-hose ID35-L80mm power gas junction (pgj)
39.2	91918541	TIG spring socket small power gas junction (pgj)
39.4	91918531	Cable support spring L125mm for power gas junction (pgj)
40	91900701	Terminal nut insulated fits EURO central adapter
41	91900122	TIG central adapter EURO (fits separate lines)
42	91900301	TIG central adapter identical ESAB, 4 contact pins at position 3,4,5,6
42.1	91918561	TIG power gas junction (pgj) fits ESAB central adapter
43	91900901	Coupling nut IT-M10x1 (rounded edges) fits EURO central adapter
44	9190411n	Power/gas plug fits Lorch / Merkle with 2 O-rings / power connection like pgj
44.1	81600001	O-ring ID8-W1,6mm fits Lorch/Merkle
45	91918326	Power/gas plug fits Fronius with 1 O-ring / power connection like pgj
45.1	62190001	O-ring ID6,2-W1,9mm fits Fronius
46	9190416e	Power/gas plug fits Dalex with 1 O-ring / power connection like pgj
46.1	63240001	O-ring ID6,3-W2,4mm fits Dalex
47	9190422n	Power/gas plug fits Oerlikon with 1 O-ring / power connection like pgj
47.1	60717801	O-ring ID6,07-W1,78mm fits Oerlikon
48	9190421n	Power/gas plug fits Lorch Sk35 + gas-nipple / power connection like pgj
48.1	91900801	O-ring ID4-W1mm fits gas-nipple EURO central adapter
N.i.	91900552	TIG cable support long (like MIG-MAG) with screws fits ESAB central adapter
N.i.	91900554	Attachment screw M4x8mm fits ESAB central adapter
49	91900556	TIG cable support short with screws (fits gas-cooled)
N.i.	91920702	Screw M3x11,5mm for Ratio/Industry/RAUCH handle and cable support
N.i.	91920703	M3 mounting socket for Ratio/Industry/RAUCH handle and cable support
o.A.	91900602	Screw M4x6mm for TIG cable support short
49.1	91901012	Reduction-eyelet (rubber) from ID10,5mm to ID5mm fits TIG cable support short
50	91912801	Spring-socket EURO central adapter
51	91912601	Cable support spring fits EURO / ESAB central adapter
67.1	21089021	Gas nozzle gasket dagged
71	21096101	Gas lens 210-S / 1,0
71	21096161	Gas lens 210-S / 1,6
71	21096241	Gas lens 210-S / 2,4
71	21096321	Gas lens 210-S / 3,2
75	17105002	Collet L50mm SR 17-18-26 wp-18SC / 1,0 10N22

Welding-torch TIG gas-cooled**240A at 100% duty cycle (DC) - 200A at 100% duty cycle (AC)**

Art.-No.		
75	17165002	Collet L50mm SR 17-18-26 wp-18SC / 1,6 10N23
75	17245002	Collet L50mm SR 17-18-26 wp-18SC / 2,4 10N24
75	18325002	Collet L50mm SR 17-18-26 wp-18SC / 3,2 10N25
90	22093041	Gas nozzle for gas lens L42mm / Gr.4 54N18 (pu=10pieces)
90	22093051	Gas nozzle for gas lens L42mm / Gr.5 54N17 (pu=10pieces)
90	22093061	Gas nozzle for gas lens L42mm / Gr.6 54N16 (pu=10pieces)
90	22093071	Gas nozzle for gas lens L42mm / Gr.7 54N15 (pu=10pieces)
90	22093081	Gas nozzle for gas lens L42mm / Gr.8 54N14 (pu=10pieces)
90	22093111	Gas nozzle for gas lens L42mm / Gr.11 54N19-11 (pu=10pieces)
90	22093121	Gas nozzle for gas lens L42mm / Gr.12 54N19 (pu=10pieces)
N.i.	22093054	Gas nozzle for gas lens L76mm / Gr.5 54N17L (pu=10pieces)
N.i.	22093064	Gas nozzle for gas lens L76mm / Gr.6 54N16L (pu=10pieces)
N.i.	22093074	Gas nozzle for gas lens L76mm / Gr.7 54N15L (pu=10pieces)
N.i.	22093084	Gas nozzle for gas lens L76mm / Gr.8 54N14L (pu=10pieces)

Top quality tungsten electrodes in 9 different qualities, see appendix A.

Torch AUT 230-S gas-cooled



Holch Schweißbrenner GmbH
Bühlstraße 14
D-57080 Siegen

Phone: +49(0)271 387860-11
Telefax: +49(0)271 387860-29
E-Mail: info@holch-siegen.de
Web: www.holch-siegen.de

AUT 230-S gas-cooled



240 Ampere at 100% duty cycle (DC) - 200 Ampere at 100% duty cycle (AC)

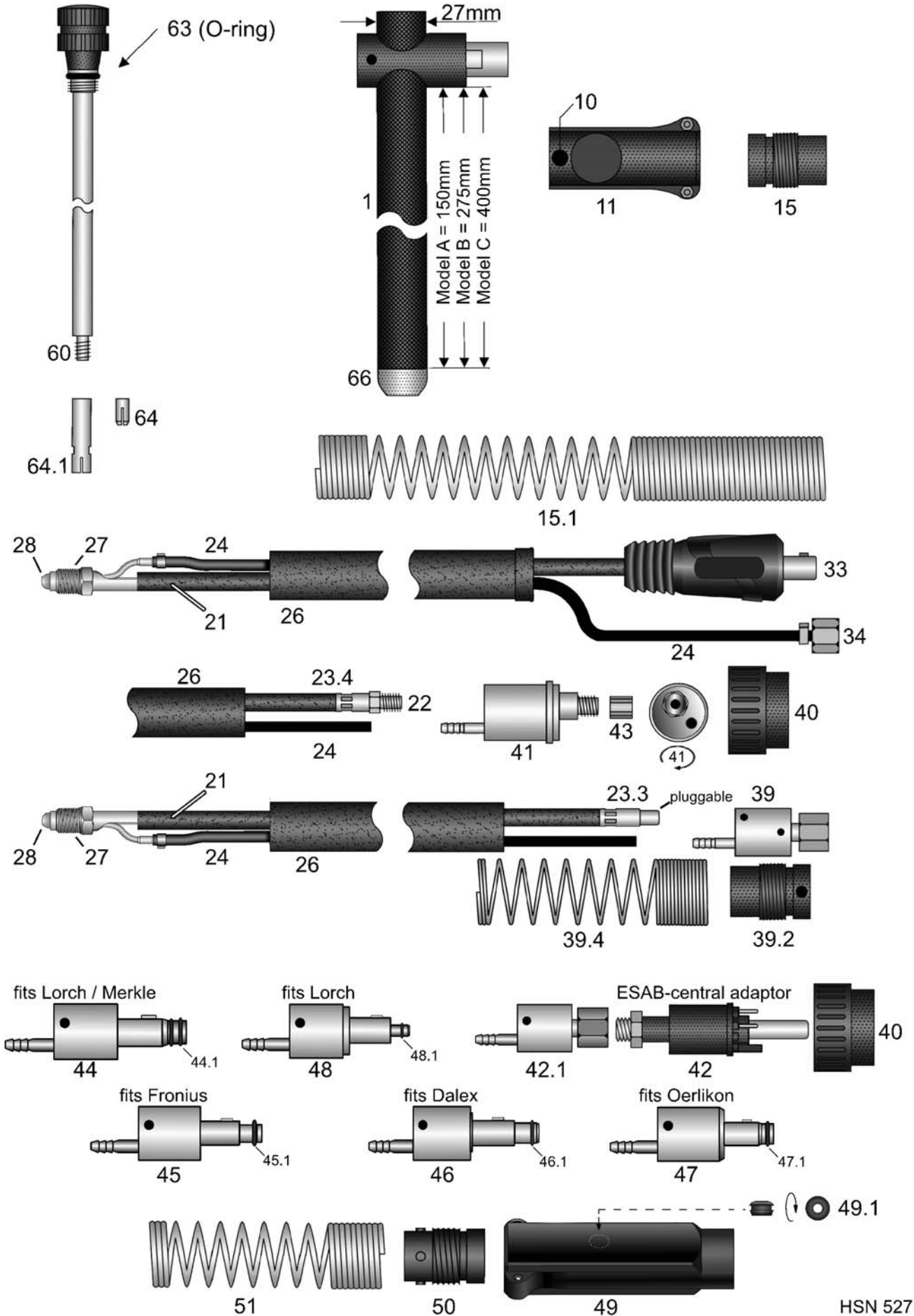

HSN 527

AUT 230 - S gas-cooled spare parts

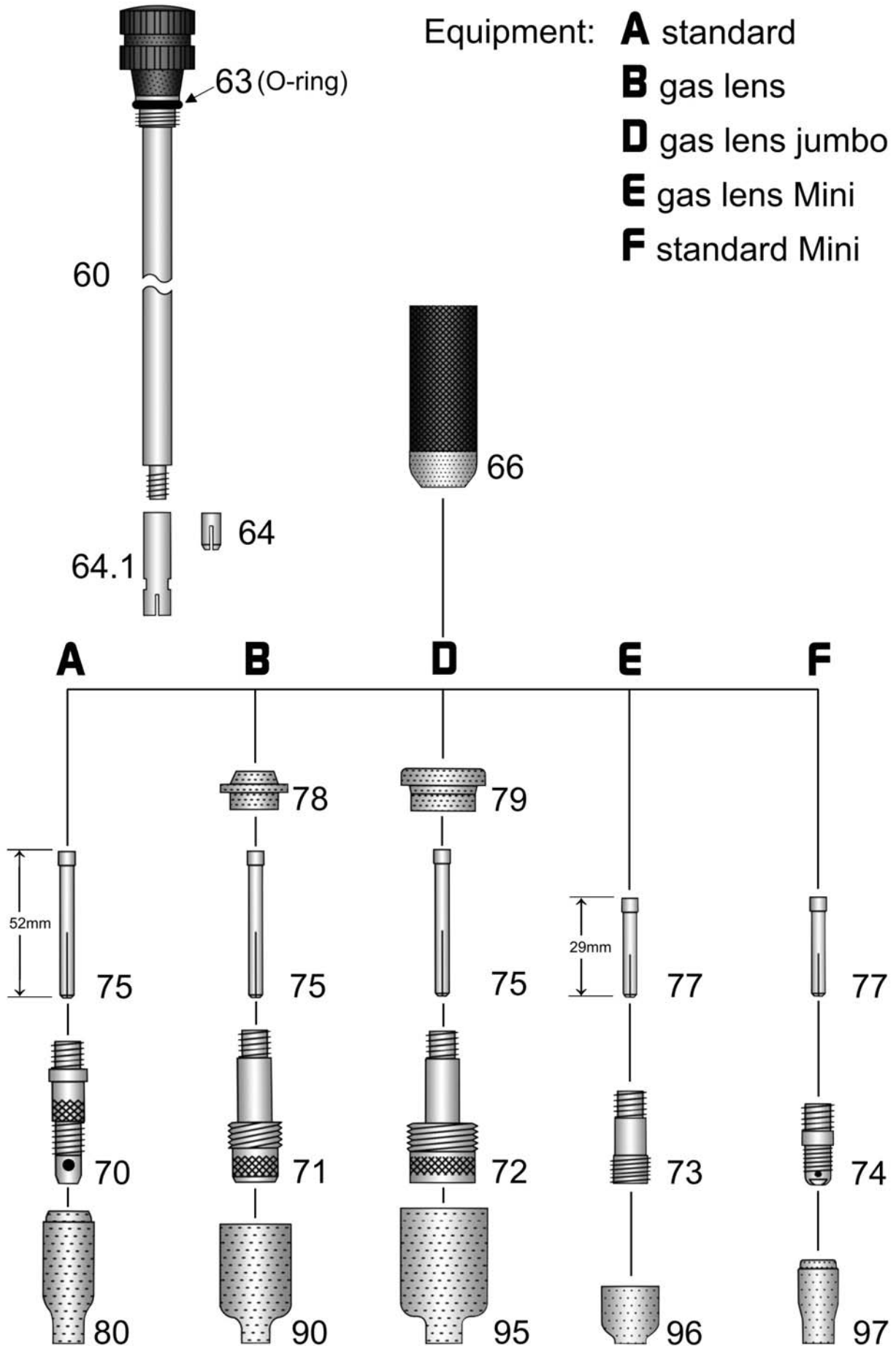

HSN 108

Welding-torch TIG gas-cooled**240A at 100% duty cycle (DC) - 200A at 100% duty cycle (AC)****Art.-No.****Torches without leatherhose. Machine side separate connections.****Torches and cable assemblies can be produced in excess lengths. Please find the different options and surcharges in the attachment "Custom made products" appendix C. We produce torches for more than 40 different brands of machines with different connection systems.**

26500401 AUTomatic-torch 230-S design "A" / 4m

26510401 AUTomatic-torch 230-S design "B" / 4m

26520401 AUTomatic-torch 230-S design "C" / 4m

26500801 AUTomatic-torch 230-S design "A" / 8m

26510801 AUTomatic-torch 230-S design "B" / 8m

26520801 AUTomatic-torch 230-S design "C" / 8m

TIG-spare cable assemblies in different qualities, machine side with separate connections and Tichel plug, or, if ordered so, with the following connection systems:

wig92401 TIG-spare cable assembly gas-cooled 4m - please state desired design!

wig92801 TIG-spare cable assembly gas-cooled 8m - please state desired design!

The following surcharges for machine side connections are only to find prices quickly. Please use our catalogue "TIG machine side connections" to find a "T" number which identifies a machine side connection system completely.

29000101 Surcharge: machine side with EURO central adapter

29002005 Surcharge: machine side power/gas plug fits Lorch/Merkle with 2 O-rings

29002004 Surcharge: machine side power/gas plug fits Fronius with 1 O-ring

29002006 Surcharge: machine side power/gas plug fits Dalex with 1 O-ring

29002107 Surcharge: machine side power/gas plug fits Oerlikon with 1 O-ring

29002002 Surcharge: machine side power/gas plug fits Lorch SK35 + gas-nipple

29000112 Surcharge: machine side fits ESAB central adapter, 4 pins installed at position 3,4,5,6

1-A 26591001 AUTomatic-torch body design "A"

1-B 26519101 AUTomatic-torch body design "B"

1-C 26529101 AUTomatic-torch body design "C"

10 18588101 Attachment screw plastic M5x8mm 230-S / 410-S

11 18588001 AUT-cable support 230-S / 410-S

15 91918541 TIG spring socket small power gas junction (pgj)

15.1 91912511 AUT cable support spring (long design)

20 26940403 Power cable 35mm² SR 26 / 4m fits power/gas plugs + power gas junction (pgj)20 26940803 Power cable 35mm² SR 26 / 8m fits power/gas plugs + power gas junction (pgj)21 26940402 Power cable 35mm² SR 26 / 4m with SK25 or SK-35 <--- please state!21 26940802 Power cable 35mm² SR 26 / 8m with SK25 or SK-35 <--- please state!22 26940404 Power cable 35mm² SR 26 / 4m EURO fits central adapter (OT-M10x1)22 26940804 Power cable 35mm² SR 26 / 8m EURO fits central adapter (OT-M10x1)23.3 22089057 TIG-Power cable connector plugable ID8,2mm fits 35mm²23.4 22089054 TIG-Power cable connector OT-M10x1 ID8,2mm fits 35mm²**Reel goods:****Prices are per meter and only applicable for purchasing of complete rolls**

Welding-torch TIG gas-cooled**240A at 100% duty cycle (DC) - 200A at 100% duty cycle (AC)**

Art.-No.		
24	41500001	Meter ST 70 PVC hose ID4,0-W1,5mm black for gas (100m)
26	22150002	Meter neoprene protective hose ID22mm black (40m)
27	91907601	Power cable connector separate lines OT-5/8"UNF-right-hand thread
28	91907613	Hose connector L64,5mm AUT 230-S pistol side
33	91918201	Powercable-plug SK-25 bayonet connection AD8mm
33	91918301	Powercable-plug SK-35 bayonet connection AD13mm
34	91901501	Coupling nut IT-G1/4"
N.i.	91901211	Hose connector 4mm fits coupling nut R1/4"
39	91918521	TIG power gas junction (pgj) with connection: IT-G1/8"
39	91918522	TIG power gas junction (pgj) with connection: IT-G1/4"
39	91918523	TIG power gas junction (pgj) with connection: IT-G3/8"
N.i.	91918551	Attachment screw (plastic) M5x12mm for power gas junction (pgj)
N.i.	91918552	3 grommets for attachment screws M5x12mm power gas junction (pgj)
N.i.	91918542	Section of insulating-hose ID35-L80mm power gas junction (pgj)
39.2	91918541	TIG spring socket small power gas junction (pgj)
39.4	91918531	Cable support spring L125mm for power gas junction (pgj)
40	91900701	Terminal nut insulated fits EURO central adapter
41	91900122	TIG central adapter EURO (fits separate lines)
42	91900301	TIG central adapter identical ESAB, 4 contact pins at position 3,4,5,6
42.1	91918561	TIG power gas junction (pgj) fits ESAB central adapter
43	91900901	Coupling nut IT-M10x1 (rounded edges) fits EURO central adapter
44	9190411n	Power/gas plug fits Lorch / Merkle with 2 O-rings / power connection like pgj
44.1	81600001	O-ring ID8-W1,6mm fits Lorch/Merkle
45	91918326	Power/gas plug fits Fronius with 1 O-ring / power connection like pgj
45.1	62190001	O-ring ID6,2-W1,9mm fits Fronius
46	9190416e	Power/gas plug fits Dalex with 1 O-ring / power connection like pgj
46.1	63240001	O-ring ID6,3-W2,4mm fits Dalex
47	9190422n	Power/gas plug fits Oerlikon with 1 O-ring / power connection like pgj
47.1	60717801	O-ring ID6,07-W1,78mm fits Oerlikon
48	9190421n	Power/gas plug fits Lorch Sk35 + gas-nipple / power connection like pgj
48.1	91900801	O-ring ID4-W1mm fits gas-nipple EURO central adapter
N.i.	91900552	TIG cable support long (like MIG-MAG) with screws fits ESAB central adapter
N.i.	91900554	Attachment screw M4x8mm fits ESAB central adapter
49	91900556	TIG cable support short with screws (fits gas-cooled)
N.i.	91920702	Screw M3x11,5mm for Ratio/Industry/RAUCH handle and cable support
N.i.	91920703	M3 mounting socket for Ratio/Industry/RAUCH handle and cable support
o.A.	91900602	Screw M4x6mm for TIG cable support short
49.1	91901012	Reduction-eyelet (rubber) from ID10,5mm to ID5mm fits TIG cable support short
50	91912801	Spring-socket EURO central adapter
51	91912601	Cable support spring fits EURO / ESAB central adapter
60-A	17591302	AUTomatic-back cap design "A"
60-B	17519131	AUTomatic-back cap design "B"

Welding-torch TIG gas-cooled**240A at 100% duty cycle (DC) - 200A at 100% duty cycle (AC)**

Art.-No.		
60-C	17529131	AUTomatic-back cap design "C"
63	10089061	O-ring ID12-W3mm
64	17101401	Electrode fixation collet 1,0
64	17161401	Electrode fixation collet 1,6
64	17241401	Electrode fixation collet 2,4
64	18321401	Electrode fixation collet 3,2
64.1	17591303	Electrode fixation collet-body
66	17289022	PTFE-isolator AUT 230/410-S
70	17961002	Collet body 17-18-26-220 / 1,0 10N30
70	17961602	Collet body 17-18-26-220 / 1,6 10N31
70	17962402	Collet body 17-18-26-220 / 2,4 10N32
70	18963202	Collet body 17-18-26-220 / 3,2 10N28
71	17961011	Gas lens 17-18-26-220 / 1,0 45V24
71	17961611	Gas lens 17-18-26-220 / 1,6 45V25
71	17962411	Gas lens 17-18-26-220 / 2,4 45V26
71	18963211	Gas lens 17-18-26-220 / 3,2 45V27
72	17961021	Jumbo gas lens 17-18-26-220 / 1,0 45V0204
72	17961621	Jumbo gas lens 17-18-26-220 / 1,6 45V116
72	17962421	Jumbo gas lens 17-18-26-220 / 2,4 45V64
72	18963221	Jumbo gas lens 17-18-26-220 / 3,2 995795
73	17961031	Gas lens "Mini" SR 17-18-26 / 1,0 conversion kit
73	17961631	Gas lens "Mini" SR 17-18-26 / 1,6 conversion kit
73	17962431	Gas lens "Mini" SR 17-18-26 / 2,4 conversion kit
73	18963231	Gas lens "Mini" SR 17-18-26 / 3,2 conversion kit
74	18961003	Collet body "Mini" SR 17-18-26 1,0 conversion kit
74	18961603	Collet body "Mini" SR 17-18-26 1,6 conversion kit
74	18962403	Collet body "Mini" SR 17-18-26 2,4 conversion kit
74	18963203	Collet body "Mini" SR 17-18-26 / 1,0 - 3,2 17CB20 conversion kit

Brazen collets L-52mm**suitable equipment line (A) standard collet body****suitable equipment line (B) gas lens****suitable equipment line (D) gas lens jumbo**

75	17105202	Collet L52mm AS17-AS18-ABL220 / 1,0 10N22-D
75	17165202	Collet L52mm AS17-AS18-ABL220 / 1,6 10N23-D
75	17245202	Collet L52mm AS17-AS18-ABL220 / 2,4 10N24-D
75	18325202	Collet L52mm AS17-AS18-ABL220 / 3,2 10N25-D

Copper-collets L-29mm**suitable equipment line (E) gas lens mini****suitable equipment line (F) standard collet body mini**

77	17103002	Collet L29mm SR 17-18-26 "Mini" 1,0 10N22S
77	17163002	Collet L29mm SR 17-18-26 "Mini" 1,6 10N23S
77	17243002	Collet L29mm SR 17-18-26 "Mini" 1,6 10N23S
77	18323002	Collet L29mm SR 17-18-26 "Mini" 3,2 10N25S

Welding-torch TIG gas-cooled**240A at 100% duty cycle (DC) - 200A at 100% duty cycle (AC)**

Art.-No.			
78	17089021	PTFE-Gas-lens insulator 17-18-26-220	54N01
79	17089031	PTFE-Gas-lens insulator Jumbo 17-18-26-220	54N63
Ceramic gas nozzles in different lengths suitable equipment line (A) standard collet body			
80	17930401	Ceramic gas nozzle L47mm 17-18-26-220 / Gr.4	10N50 (pu=10pieces)
80	17930501	Ceramic gas nozzle L47mm 17-18-26-220 / Gr.5	10N49 (pu=10pieces)
80	17930601	Ceramic gas nozzle L47mm 17-18-26-220 / Gr.6	10N48 (pu=10pieces)
80	17930701	Ceramic gas nozzle L47mm 17-18-26-220 / Gr.7	10N47 (pu=10pieces)
80	17930801	Ceramic gas nozzle L47mm 17-18-26-220 / Gr.8	10N46 (pu=10pieces)
80	17930101	Ceramic gas nozzle L47mm 17-18-26-220 / Gr.10	10N45 (pu=10pieces)
80	17930121	Ceramic gas nozzle L47mm 17-18-26-220 / Gr.12	10N44 (pu=10pieces)
N.i.	17930404	Ceramic gas nozzle L76mm 17-18-26-220 / Gr.4	10N50L (pu=10pieces)
N.i.	17930504	Ceramic gas nozzle L76mm 17-18-26-220 / Gr.5	10N49L (pu=10pieces)
N.i.	17930604	Ceramic gas nozzle L76mm 17-18-26-220 / Gr.6	10N48L (pu=10pieces)
N.i.	17930704	Ceramic gas nozzle L76mm 17-18-26-220 / Gr.7	10N47L (pu=10pieces)
Ceramic gas nozzles in different lengths suitable equipment line (B) gas lens			
90	22093041	Gas nozzle for gas lens L42mm / Gr.4	54N18 (pu=10pieces)
90	22093051	Gas nozzle for gas lens L42mm / Gr.5	54N17 (pu=10pieces)
90	22093061	Gas nozzle for gas lens L42mm / Gr.6	54N16 (pu=10pieces)
90	22093071	Gas nozzle for gas lens L42mm / Gr.7	54N15 (pu=10pieces)
90	22093081	Gas nozzle for gas lens L42mm / Gr.8	54N14 (pu=10pieces)
90	22093111	Gas nozzle for gas lens L42mm / Gr.11	54N19-11 (pu=10pieces)
90	22093121	Gas nozzle for gas lens L42mm / Gr.12	54N19 (pu=10pieces)
N.i.	22093054	Gas nozzle for gas lens L76mm / Gr.5	54N17L (pu=10pieces)
N.i.	22093064	Gas nozzle for gas lens L76mm / Gr.6	54N16L (pu=10pieces)
N.i.	22093074	Gas nozzle for gas lens L76mm / Gr.7	54N15L (pu=10pieces)
N.i.	22093084	Gas nozzle for gas lens L76mm / Gr.8	54N14L (pu=10pieces)
Ceramic gas nozzles jumbo in different lengths suitable equipment line (D) gas lens jumbo			
95	22093066	Jumbo gas nozzle L48mm / Gr.6	57N75 (pu=10pieces)
95	22093086	Jumbo gas nozzle L48mm / Gr.8	57N74 (pu=10pieces)
95	22093106	Jumbo gas nozzle L48mm / Gr.10	53N88 (pu=10pieces)
95	22093126	Jumbo gas nozzle L48mm / Gr.12	53N87 (pu=10pieces)
N.i.	22093067	Jumbo gas nozzle L73mm / Gr.6	57N75L (pu=10pieces)
N.i.	22093087	Jumbo gas nozzle L73mm / Gr.8	57N74L (pu=10pieces)
N.i.	22093107	Jumbo gas nozzle L73mm / Gr.10	53N88L (pu=10pieces)
N.i.	22093127	Jumbo gas nozzle L73mm / Gr.12	53N87L (pu=10pieces)
Ceramic gas nozzles L-20mm suitable equipment line (E) gas lens mini			
96	17930502	Ceramic gas nozzle L20mm SR 17-18-26 / Gr.5 fits gas lens "Mini"	53N59MS (pu=10pieces)
96	17930602	Ceramic gas nozzle L20mm SR 17-18-26 / Gr.6 fits gas lens "Mini"	53N60MS (pu=10pieces)
96	17930702	Ceramic gas nozzle L20mm SR 17-18-26 / Gr.7 fits gas lens "Mini"	53N61MS (pu=10pieces)

Welding-torch TIG gas-cooled**240A at 100% duty cycle (DC) - 200A at 100% duty cycle (AC)****Art.-No.**

Ceramic gas nozzles suitable equipment line (F) collet body standard mini				
97	20930401	Ceramic gas nozzle L30mm / Gr. 4	13N08	(pu=10pieces)
97	20930501	Ceramic gas nozzle L30mm / Gr. 5	13N09	(pu=10pieces)
97	20930601	Ceramic gas nozzle L30mm / Gr. 6	13N10	(pu=10pieces)
97	20930701	Ceramic gas nozzle L30mm / Gr. 7	13N11	(pu=10pieces)
97	20930801	Ceramic gas nozzle L30mm / Gr. 8	13N12	(pu=10pieces)
97	20930101	Ceramic gas nozzle L30mm / Gr.10	13N13	(pu=10pieces)
N.i.	20930304	Ceramic gas nozzle L48mm / Gr. 3	796F70	(pu=10pieces)
N.i.	20930404	Ceramic gas nozzle L48mm / Gr. 4	796F71	(pu=10pieces)
N.i.	20930504	Ceramic gas nozzle L48mm / Gr. 5	796F72	(pu=10pieces)
o.A	20930604	Ceramic gas nozzle L48mm / Gr. 6	796F73	(pu=10pieces)
N.i.	20930306	Ceramic gas nozzle L63mm / Gr. 3	796F74	(pu=10pieces)
N.i.	20930406	Ceramic gas nozzle L63mm / Gr. 4	796F75	(pu=10pieces)
N.i.	20930506	Ceramic gas nozzle L63mm / Gr. 5	796F76	(pu=10pieces)
N.i.	20930606	Ceramic gas nozzle L63mm / Gr. 6	796F77	(pu=10pieces)
N.i.	20930408	Ceramic gas nozzle L89mm / Gr. 4	796F79	(pu=10pieces)
Top quality tungsten electrodes in 9 different qualities, see appendix A.				

Torch AUT 410-S water-cooled



Holch Schweißbrenner GmbH
Bühlstraße 14
D-57080 Siegen

Phone: +49(0)271 387860-11
Telefax: +49(0)271 387860-29
E-Mail: info@holch-siegen.de
Web: www.holch-siegen.de

AUT 410-S water-cooled



400 Ampere at 100% duty cycle (DC) - 320 Ampere at 100% duty cycle (AC)

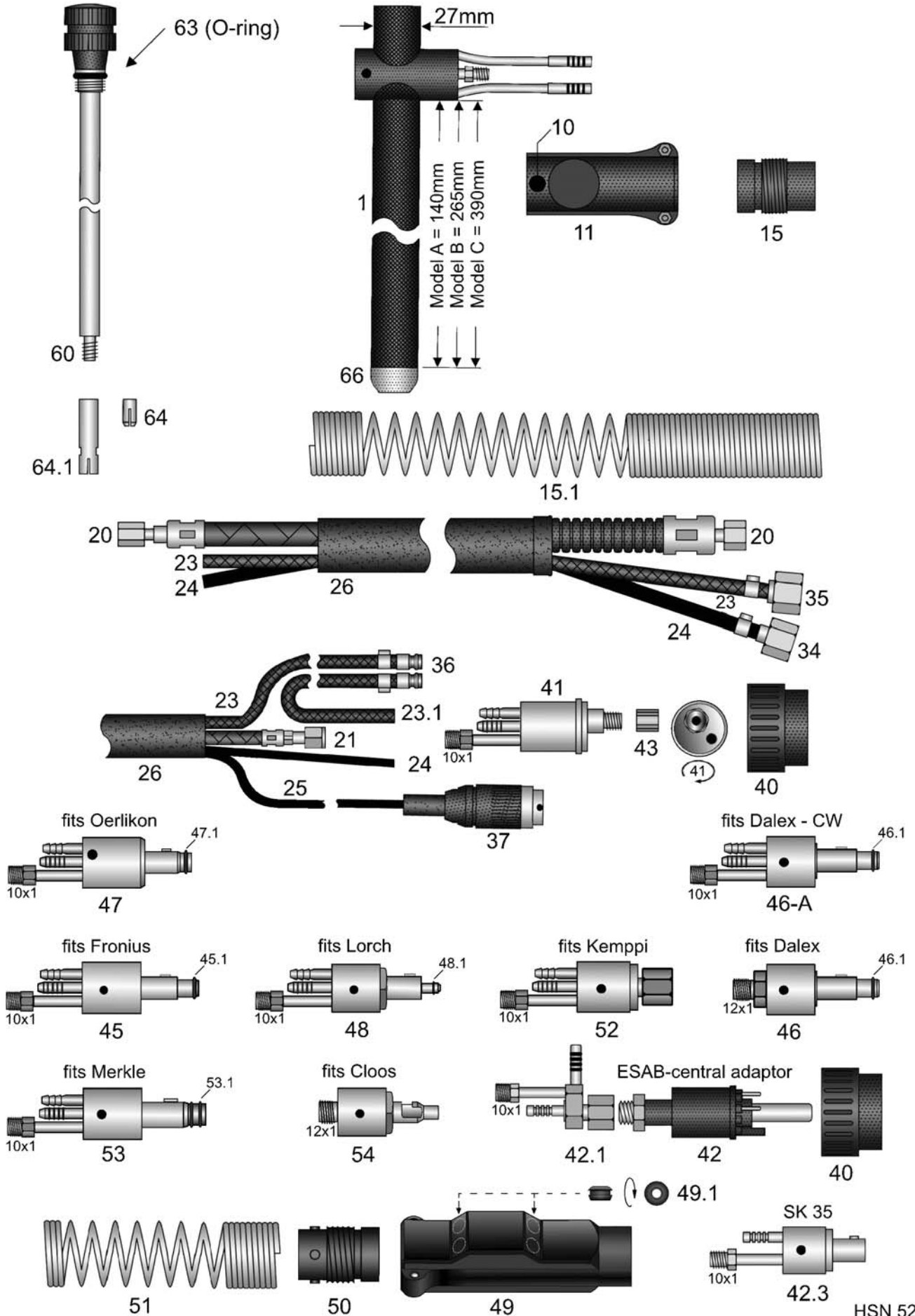

HSN 528



AUT 410 - S water-cooled spare parts

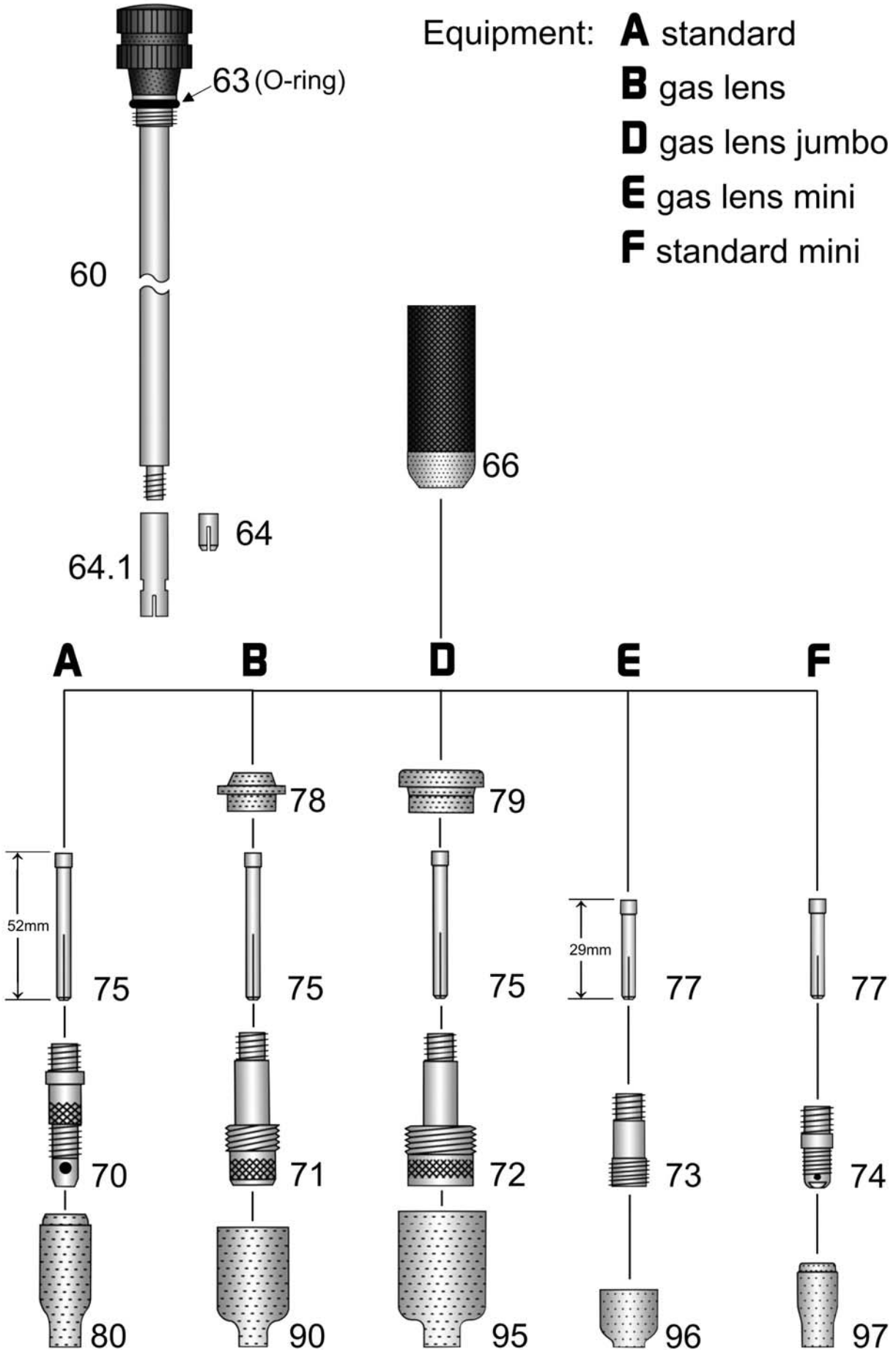

HSN 110

Welding-torch TIG water-cooled**400A at 100% duty cycle (DC) - 320A at 100% duty cycle (AC)****Art.-No.****Torches without leatherhose. Machine side separate connections.**

In variation to the torches listed below, the torches can also be produced with other power/water cables (e.g. HT 180 silicone superflexible). This can also be combined with hoses in a lot of different qualities. Torches and cable assemblies can be produced in excess lengths. Please find the different options and surcharges in the attachment "Custom made products" appendix C. We produce torches for more than 40 different brands of machines with different connection systems.

18500401	AUTomatic-torch 410-S design "A" / 4m spare cable assembly ST 80 PVC-NIT
18510401	AUTomatic-torch 410-S design "B" / 4m spare cable assembly ST 80 PVC-NIT
18520401	AUTomatic-torch 410-S design "C" / 4m spare cable assembly ST 80 PVC-NIT

18500801	AUTomatic-torch 410-S design "A" / 8m spare cable assembly ST 80 PVC-NIT
18510801	AUTomatic-torch 410-S design "B" / 8m spare cable assembly ST 80 PVC-NIT
18520801	AUTomatic-torch 410-S design "C" / 8m spare cable assembly ST 80 PVC-NIT

The following torches are equipped with very flexible and heat resistant HT110 rubber fabric hoses.

1850040P	AUTomatic-torch design "A" / 4m spare cable assembly HT 110
1851040P	AUTomatic torch design "B" / 4m spare cable assembly HT 110
1852040P	AUTomatic torch design "C" / 4m spare cable assembly HT 110

1850080P	AUTomatic torch design "A" / 8m spare cable assembly HT 110
1851080P	AUTomatic torch design "B" / 8m spare cable assembly HT 110
1852080P	AUTomatic torch design "C" / 8m spare cable assembly HT 110

TIG-spare cable assemblies in different qualities, machine side with separate connections and Tichel plug, or, if ordered so, with the following connection systems:

wig92402	TIG-spare cable assembly water-cooled 4m - please state desired design!
wig92802	TIG-spare cable assembly water-cooled 8m - please state desired design!

The following surcharges for machine side connections are only to find prices quickly. Please use our catalogue "TIG machine side connections" to find a "T" number which identifies a machine side connection system completely.

29002102	Surcharge: machine side power/water plug SK35 bayonet connection AD13mm
29000201	Surcharge: machine side with EURO central adapter
29002109	Surcharge: machine side power/water plug fits Merkle with 2 O-rings
29002106	Surcharge: machine side power/water plug fits Fronius with 1 O-ring
29002101	Surcharge: machine side power/water plug fits Dalex with 1 O-ring
29002108	Surcharge: machine side power/water plug fits Oerlikon with 1 O-ring
29002104	Surcharge: machine side power/water plug fits Lorch SK35 + gas-nipple
29002105	Surcharge: machine side power/water plug fits Kemppi IT-G1/4"
29002110	Surcharge: machine side power/water plug fits Cloos
29000212	Surcharge: machine side fits ESAB central adapter, 4 pins installed at position 3,4,5,6

1-A	18591001	AUTomatic-torch body design "A"
1-B	18519101	AUTomatic-torch body design "B"
1-C	18529101	AUTomatic-torch body design "C"

10	18588101	Attachment screw plastic M5x8mm 230-S / 410-S
11	18588001	AUT-cable support 230-S / 410-S

Welding-torch TIG water-cooled**400A at 100% duty cycle (DC) - 320A at 100% duty cycle (AC)**

Art.-No.		
15	91918541	TIG spring socket small power gas junction (pgj)
15.1	91912511	AUT cable support spring (long design)
Please state the machine side connection for the following power/water cables. For 4m long torches:		
20	18594401	Power/water cable 17,31mm ² 410-S / 4m MG
20	18594404	HT 105 PVC-NIT power/water cable 17,31mm ² 410-S / 4m
20	18594403	HT 110 rubber fabric hose power/water cable 17,31mm ² 410-S / 4m
20	18594405	HT 130 TPE power/water cable 17,31mm ² 410-S / 4m
20	18594408	HT 180 silicone super flexible power/water cable 17,31mm ² 410-S / 4m
For 8m long torches:		
20	18594801	Power/water cable 17,31mm ² 410-S / 8m MG
20	18594804	HT 105 PVC-NIT power/water cable 17,31mm ² 410-S / 8m
20	18594803	HT 110 rubber fabric hose power/water cable 17,31mm ² 410-S / 8m
20	18594805	HT 130 TPE power/water cable 17,31mm ² 410-S / 8m
20	18594808	HT 180 silicone super flexible power/water cable 17,31mm ² 410-S / 8m
The following power/water cables are produced with M10x1 inner thread at the machine side for EURO central adapters. (fits to all Holch connection systems with outer thread M10x1). For 4m long torches:		
21	18594411	Power/water cable 17,31mm ² 410-S / 4m EURO
21	18594414	HT 105 PVC-NIT power/water cable 17,31mm ² 410-S / 4m
21	18594413	HT 110 rubber fabric hose power/water cable 17,31mm ² 410-S / 4m
21	18594415	HT 130 TPE power/water cable 17,31mm ² 410-S / 4m
21	18594418	HT 180 silicone super flexible power/water cable 17,31mm ² 410-S / 4m
For 8m long torches:		
21	18594811	Power/water cable 17,31mm ² 410-S / 8m EURO
21	18594814	HT 105 PVC-NIT power/water cable 17,31mm ² 410-S / 8m
21	18594813	HT 110 rubber fabric hose power/water cable 17,31mm ² 410-S / 8m
21	18594815	HT 130 TPE power/water cable 17,31mm ² 410-S / 8m
21	18594818	HT 180 silicone super flexible power/water cable 17,31mm ² 410-S / 8m
Reel goods: Prices are per meter and only applicable for purchasing of complete rolls		
23	50150001	Meter ST 80 PVC-NIT fabric hose ID5,0-W1,5mm blue for water (100m)
23	51700002	Meter HT 110 rubber fabric hose ID5,0-W1,7mm blue for water (100m)
23.1	50151001	Meter ST 80 PVC-NIT fabric hose ID5,0-W1,5mm red for water (100m)
23.1	51700003	Meter HT 110 rubber fabric hose ID5,0-W1,7mm red for water (100m)
24	41500001	Meter ST 70 PVC hose ID4,0-W1,5mm black for gas (100m)
24	51700001	Meter HT 110 rubber fabric hose ID5,0-W1,7mm black for gas (100m)
24	31200001	Meter HT 130 PUR hose ID3-W1,2mm black for gas (100m)
26	22150002	Meter neoprene protective hose ID22mm black (40m)
34	91901501	Coupling nut IT-G1/4"
N.i.	91901211	Hose connector 4mm fits coupling nut R1/4"
35	91901601	Coupling nut IT-G3/8"
N.i.	91901301	Hose connector 5mm fits Coupling nut R3/8"
36	91901001	Cooling liquid plug nipples EURO
N.i.	91901008	Closing cap blue fits cooling liquid plug nipples EURO
N.i.	91901009	Closing cap red fits cooling liquid plug nipples EURO

Welding-torch TIG water-cooled**400A at 100% duty cycle (DC) - 320A at 100% duty cycle (AC)**

Art.-No.		
40	91900701	Terminal nut insulated fits EURO central adapter
41	91900211	TIG central adapter EURO central adapter water cooled
42	91900301	TIG central adapter identical ESAB, 4 contact pins at position 3,4,5,6
42.1	91918571	TIG power/cooling liquid junction fits ESAB central adapter
42.3	91918312	TIG central adapter SK-35 bayonet connection AD13mm
43	91900901	Coupling nut IT-M10x1 (rounded edges) fits EURO central adapter
45	91918327	Power/water plug fits Fronius with 1 O-ring (OT-M10x1 / like EURO central adapter)
45.1	62190001	O-ring ID6,2-W1,9mm fits Fronius
46	9190417e	Power/water plug fits Dalex (1 O-ring) (OT-12x1)
46-A	9190418n	Power-/gasplug fits Dalex with waterdeviation to outside, CW-System with 1 O-ring
46.1	63240001	O-ring ID6,3-W2,4mm fits Dalex
47	9190423n	Power/water plug fits Oerlikon with 1 O-ring (OT-M10x1 / like EURO central adapter)
47.1	60717801	O-ring ID6,07-W1,78mm fits Oerlikon
48	9190420n	Power/water plug fits Lorch SK35 + gas-nipple (OT-10x1 / like EURO central adapter)
48.1	91900801	O-ring ID4-W1mm fits gas-nipple EURO central adapter
o.A	91900552	TIG cable support long (like MIG-MAG) with screws fits ESAB central adapter
N.i.	91900554	Attachment screw M4x8mm fits ESAB central adapter
49	91900557	TIG cable support short with screws (fits water-cooled)
N.i.	91920702	Screw M3x11,5mm for Ratio/Industry/RAUCH handle and cable support
N.i.	91920703	M3 mounting socket for Ratio/Industry/RAUCH handle and cable support
o.A.	91900602	Screw M4x6mm for TIG cable support short
49.1	91901012	Reduction-eyelet (rubber) from ID10,5mm to ID5mm fits TIG cable support short
N.i.	91921701	PUR hose ID8,5-W1,0mm 150mm long fits leading water hoses into cable support
50	91912801	Spring-socket EURO central adapter
51	91912601	Cable support spring fits EURO / ESAB central adapter
52	9190419n	Power/water plug fits Kemppi IT-G1/4" (AG-M10x1 / like EURO central adapter)
53	9190424n	Power/water plug fits Merkle with 2 O-rings (OT-M10x1 / like EURO central adapter)
53.1	81600001	O-ring ID8-W1,6mm fits Lorch/Merkle
54	9190415n	Powerplug fits Cloos (special-plug) (OT-12x1)
60-A	17591302	AUTomatic-back cap design "A"
60-B	17519131	AUTomatic-back cap design "B"
60-C	17529131	AUTomatic-back cap design "C"
63	10089061	O-ring ID12-W3mm
64	17101401	Electrode fixation collet 1,0
64	17161401	Electrode fixation collet 1,6
64	17241401	Electrode fixation collet 2,4
64	18321401	Electrode fixation collet 3,2
64	18401401	Electrode fixation collet 4,0
64.1	17591303	Electrode fixation collet-body
66	17289022	PTFE-isolator AUT 230/410-S
70	17961002	Collet body 17-18-26-220 / 1,0 10N30
70	17961602	Collet body 17-18-26-220 / 1,6 10N31
70	17962402	Collet body 17-18-26-220 / 2,4 10N32

Welding-torch TIG water-cooled**400A at 100% duty cycle (DC) - 320A at 100% duty cycle (AC)**

Art.-No.		
70	18963202	Collet body 17-18-26-220 / 3,2 10N28
70	18964002	Collet body 17-18-26-220 / 4,0 406488
71	17961011	Gas lens 17-18-26-220 / 1,0 45V24
71	17961611	Gas lens 17-18-26-220 / 1,6 45V25
71	17962411	Gas lens 17-18-26-220 / 2,4 45V26
71	18963211	Gas lens 17-18-26-220 / 3,2 45V27
71	18964011	Gas lens 17-18-26-220 / 4,0 45V28
72	17961021	Jumbo gas lens 17-18-26-220 / 1,0 45V0204
72	17961621	Jumbo gas lens 17-18-26-220 / 1,6 45V116
72	17962421	Jumbo gas lens 17-18-26-220 / 2,4 45V64
72	18963221	Jumbo gas lens 17-18-26-220 / 3,2 995795
72	18964021	Jumbo gas lens 17-18-26-220 / 4,0 45V63
73	17961031	Gas lens "Mini" SR 17-18-26 / 1,0 conversion kit
73	17961631	Gas lens "Mini" SR 17-18-26 / 1,6 conversion kit
73	17962431	Gas lens "Mini" SR 17-18-26 / 2,4 conversion kit
73	18963231	Gas lens "Mini" SR 17-18-26 / 3,2 conversion kit
74	18961003	Collet body "Mini" SR 17-18-26 1,0 conversion kit
74	18961603	Collet body "Mini" SR 17-18-26 1,6 conversion kit
74	18962403	Collet body "Mini" SR 17-18-26 2,4 conversion kit
74	18963203	Collet body "Mini" SR 17-18-26 / 1,0 - 3,2 17CB20 conversion kit
<p>Brazen collets L-52mm suitable equipment line (A) standard collet body suitable equipment line (B) gas lens suitable equipment line (D) gas lens jumbo</p>		
75	17105202	Collet L52mm AS17-AS18-ABL220 / 1,0 10N22-D
75	17165202	Collet L52mm AS17-AS18-ABL220 / 1,6 10N23-D
75	17245202	Collet L52mm AS17-AS18-ABL220 / 2,4 10N24-D
75	18325202	Collet L52mm AS17-AS18-ABL220 / 3,2 10N25-D
75	18405202	Collet L52mm AS17-AS18-ABL220 / 4,0 54N20-D
<p>Copper-collets L-29mm suitable equipment line (E) gas lens mini suitable equipment line (F) standard collet body mini</p>		
77	17103002	Collet L29mm SR 17-18-26 "Mini" 1,0 10N22S
77	17163002	Collet L29mm SR 17-18-26 "Mini" 1,6 10N23S
77	17243002	Collet L29mm SR 17-18-26 "Mini" 1,6 10N23S
77	18323002	Collet L29mm SR 17-18-26 "Mini" 3,2 10N25S
78	17089021	PTFE-Gas-lens insulator 17-18-26-220 54N01
79	17089031	PTFE-Gas-lens insulator Jumbo 17-18-26-220 54N63
<p>Ceramic gas nozzles in different lengths suitable equipment line (A) standard collet body</p>		
80	17930401	Ceramic gas nozzle L47mm 17-18-26-220 / Gr.4 10N50 (pu=10pieces)
80	17930501	Ceramic gas nozzle L47mm 17-18-26-220 / Gr.5 10N49 (pu=10pieces)
80	17930601	Ceramic gas nozzle L47mm 17-18-26-220 / Gr.6 10N48 (pu=10pieces)
80	17930701	Ceramic gas nozzle L47mm 17-18-26-220 / Gr.7 10N47 (pu=10pieces)
80	17930801	Ceramic gas nozzle L47mm 17-18-26-220 / Gr.8 10N46 (pu=10pieces)

Welding-torch TIG water-cooled**400A at 100% duty cycle (DC) - 320A at 100% duty cycle (AC)**

Art.-No.			
80	17930101	Ceramic gas nozzle L47mm 17-18-26-220 / Gr.10 10N45	(pu=10pieces)
80	17930121	Ceramic gas nozzle L47mm 17-18-26-220 / Gr.12 10N44	(pu=10pieces)
N.i.	17930404	Ceramic gas nozzle L76mm 17-18-26-220 / Gr.4 10N50L	(pu=10pieces)
N.i.	17930504	Ceramic gas nozzle L76mm 17-18-26-220 / Gr.5 10N49L	(pu=10pieces)
N.i.	17930604	Ceramic gas nozzle L76mm 17-18-26-220 / Gr.6 10N48L	(pu=10pieces)
N.i.	17930704	Ceramic gas nozzle L76mm 17-18-26-220 / Gr.7 10N47L	(pu=10pieces)
Ceramic gas nozzles in different lengths suitable equipment line (B) gas lens			
90	22093041	Gas nozzle for gas lens L42mm / Gr.4 54N18	(pu=10pieces)
90	22093051	Gas nozzle for gas lens L42mm / Gr.5 54N17	(pu=10pieces)
90	22093061	Gas nozzle for gas lens L42mm / Gr.6 54N16	(pu=10pieces)
90	22093071	Gas nozzle for gas lens L42mm / Gr.7 54N15	(pu=10pieces)
90	22093081	Gas nozzle for gas lens L42mm / Gr.8 54N14	(pu=10pieces)
90	22093111	Gas nozzle for gas lens L42mm / Gr.11 54N19-11	(pu=10pieces)
90	22093121	Gas nozzle for gas lens L42mm / Gr.12 54N19	(pu=10pieces)
N.i.	22093054	Gas nozzle for gas lens L76mm / Gr.5 54N17L	(pu=10pieces)
N.i.	22093064	Gas nozzle for gas lens L76mm / Gr.6 54N16L	(pu=10pieces)
N.i.	22093074	Gas nozzle for gas lens L76mm / Gr.7 54N15L	(pu=10pieces)
N.i.	22093084	Gas nozzle for gas lens L76mm / Gr.8 54N14L	(pu=10pieces)
Ceramic gas nozzles jumbo in different lengths suitable equipment line (D) gas lens jumbo			
95	22093066	Jumbo gas nozzle L48mm / Gr.6 57N75	(pu=10pieces)
95	22093086	Jumbo gas nozzle L48mm / Gr.8 57N74	(pu=10pieces)
95	22093106	Jumbo gas nozzle L48mm / Gr.10 53N88	(pu=10pieces)
95	22093126	Jumbo gas nozzle L48mm / Gr.12 53N87	(pu=10pieces)
N.i.	22093067	Jumbo gas nozzle L73mm / Gr.6 57N75L	(pu=10pieces)
N.i.	22093087	Jumbo gas nozzle L73mm / Gr.8 57N74L	(pu=10pieces)
N.i.	22093107	Jumbo gas nozzle L73mm / Gr.10 53N88L	(pu=10pieces)
N.i.	22093127	Jumbo gas nozzle L73mm / Gr.12 53N87L	(pu=10pieces)
Ceramic gas nozzles L-20mm suitable equipment line (E) gas lens mini			
96	17930502	Ceramic gas nozzle L20mm SR 17-18-26 / Gr.5 fits gas lens "Mini" 53N59MS	(pu=10pieces)
96	17930602	Ceramic gas nozzle L20mm SR 17-18-26 / Gr.6 fits gas lens "Mini" 53N60MS	(pu=10pieces)
96	17930702	Ceramic gas nozzle L20mm SR 17-18-26 / Gr.7 fits gas lens "Mini" 53N61MS	(pu=10pieces)
Ceramic gas nozzles suitable equipment line (F) collet body standard mini			
97	20930401	Ceramic gas nozzle L30mm / Gr. 4 13N08	(pu=10pieces)
97	20930501	Ceramic gas nozzle L30mm / Gr. 5 13N09	(pu=10pieces)
97	20930601	Ceramic gas nozzle L30mm / Gr. 6 13N10	(pu=10pieces)
97	20930701	Ceramic gas nozzle L30mm / Gr. 7 13N11	(pu=10pieces)
97	20930801	Ceramic gas nozzle L30mm / Gr. 8 13N12	(pu=10pieces)
97	20930101	Ceramic gas nozzle L30mm / Gr.10 13N13	(pu=10pieces)
N.i.	20930304	Ceramic gas nozzle L48mm / Gr. 3 796F70	(pu=10pieces)
N.i.	20930404	Ceramic gas nozzle L48mm / Gr. 4 796F71	(pu=10pieces)
N.i.	20930504	Ceramic gas nozzle L48mm / Gr. 5 796F72	(pu=10pieces)

Welding-torch TIG water-cooled**400A at 100% duty cycle (DC) - 320A at 100% duty cycle (AC)**

Art.-No.			
o.A	20930604	Ceramic gas nozzle L48mm / Gr. 6 796F73	(pu=10pieces)
N.i.	20930306	Ceramic gas nozzle L63mm / Gr. 3 796F74	(pu=10pieces)
N.i.	20930406	Ceramic gas nozzle L63mm / Gr. 4 796F75	(pu=10pieces)
N.i.	20930506	Ceramic gas nozzle L63mm / Gr. 5 796F76	(pu=10pieces)
N.i.	20930606	Ceramic gas nozzle L63mm / Gr. 6 796F77	(pu=10pieces)
N.i.	20930408	Ceramic gas nozzle L89mm / Gr. 4 796F79	(pu=10pieces)

Top quality tungsten electrodes in 9 different qualities, see appendix A.

A

Tungsten-electrodes

Available only in packaging units (PU)

1PU = 10 pieces (Sizes 1,0 - 4,0)

1PU = 5 pieces (Size 4,8)

Art.-No.**Tungsten electrodes blue**

10175901	Tungsten-electrode WL20 1,0x175 blue
16175901	Tungsten-electrode WL20 1,6x175 blue
20175901	Tungsten-electrode WL20 2,0x175 blue
24175901	Tungsten-electrode WL20 2,4x175 blue
32175901	Tungsten-electrode WL20 3,2x175 blue
40175901	Tungsten-electrode WL20 4,0x175 blue
48175901	Tungsten-electrode WL20 4,8x175 blue

Tungsten electrodes yellow

10175501	Tungsten-electrode 1,0x175 WT10 yellow
16175501	Tungsten-electrode 1,6x175 WT10 yellow
20175501	Tungsten-electrode 2,0x175 WT10 yellow
24175501	Tungsten-electrode 2,4x175 WT10 yellow
32175501	Tungsten-electrode WT10 3,2x175 yellow
40175501	Tungsten-electrode WT10 4,0x175 yellow
48175501	Tungsten-electrode WT10 4,8x175 yellow

Tungsten electrodes gold

10175801	Tungsten-electrode WL15 1,0x175 gold
16175801	Tungsten-electrode WL15 1,6x175 gold
20175801	Tungsten-electrode WL15 2,0x175 gold
24175801	Tungsten-electrode WL15 2,4x175 gold
32175801	Tungsten-electrode WL15 3,2x175 gold
40175801	Tungsten-electrode WL15 4,0x175 gold
48175801	Tungsten-electrode WL15 4,8x175 gold

Tungsten electrodes grey

10175211	Tungsten-electrode WC20 1,0x175 grey
16175211	Tungsten-electrode WC20 1,6x175 grey
20175211	Tungsten-electrode WC20 2,0x175 grey
24175211	Tungsten-electrode WC20 2,4x175 grey
32175211	Tungsten-electrode WC20 3,2x175 grey
40175211	Tungsten-electrode WC20 4,0x175 grey
48175211	Tungsten-electrode WC20 4,8x175 grey

Tungsten electrodes green

10175001	Tungsten-electrode 1,0x175 WP green
16175001	Tungsten-electrode 1,6x175 WP green
20175001	Tungsten-electrode 2,0x175 WP green
24175001	Tungsten-electrode 2,4x175 WP green
32175001	Tungsten-electrode 3,2x175 WP green
40175001	Tungsten-electrode 4,0x175 WP green
48175001	Tungsten-electrode 4,8x175 WP green

Tungsten electrodes rot (discontinued article)

10175201	Tungsten-electrode WT20 1,0x175 red
16175201	Tungsten-electrode WT20 1,6x175 red
20175201	Tungsten-electrode WT20 2,0x175 red
24175201	Tungsten-electrode WT20 2,4x175 red
32175201	Tungsten-electrode WT20 3,2x175 red
40175201	Tungsten-electrode WT20 4,0x175 red
48175201	Tungsten-electrode WT20 4,8x175 red

Art.-No.

Tungsten electrodes black

10175701	Tungsten-electrode WL10 1,0x175 black
16175701	Tungsten-electrode WL10 1,6x175 black
20175701	Tungsten-electrode WL10 2,0x175 black
24175701	Tungsten-electrode WL10 2,4x175 black
32175701	Tungsten-electrode WL10 3,2x175 black
40175701	Tungsten-electrode WL10 4,0x175 black
48175701	Tungsten-electrode WL10 4,8x175 black

Tungsten electrodes turquoise

10175002	Tungsten-electrode WR2 1,0x175 cyan
16175002	Tungsten-electrode WR2 1,6x175 cyan
20175002	Tungsten-electrode WR2 2,0x175 cyan
24175002	Tungsten-electrode WR2 2,4x175 cyan
32175002	Tungsten-electrode WR2 3,2x175 cyan
40175002	Tungsten-electrode WR2 4,0x175 cyan
48175002	Tungsten-electrode WR2 4,8x175 cyan

Tungsten electrodes white

10175401	Tungsten-electrode WZ8 1,0x175 white
16175401	Tungsten-electrode WZ8 1,6x175 white
20175401	Tungsten-electrode WZ8 2,0x175 white
24175401	Tungsten-electrode WZ8 2,4x175 white
32175401	Tungsten-electrode WZ8 3,2x175 white
40175401	Tungsten-electrode WZ8 4,0x175 white
48175401	Tungsten-electrode WZ8 4,8x175 white

B

Sundries, parts and tools

Art.-No.	
80e00001	Hose clip 8,0-E
75e00002	Hose clip 7,5-E
87e00001	Hose clip 8,7-E
95e00001	Hose clip 9,5-E
100e0001	Hose clip 10,0-E
105e0001	Hose clip 10,5-E
9191730n	Instant glue VA-20 inviscid
9191740n	Instant glue VA-1500 viscous
9191721n	Contact tip wrench flat-steel SW 5,6,8,10,12

C

Custom made products

Art.-No.**Excess length welding torches****Hand and AUTomatic welding torches gas-cooled**

29100011	Surcharge: TIG torch or spare-cable-assembly gas-cooled length: 10m
29100012	Surcharge: TIG torch or spare-cable-assembly gas-cooled length: 12m
29100016	Surcharge: TIG torch or spare-cable-assembly gas-cooled length: 16m
29100020	Surcharge: TIG torch or spare-cable-assembly gas-cooled length: 20m
29100024	Surcharge: TIG torch or spare-cable-assembly gas-cooled length: 24m

Hand and AUTomatic welding torches water-cooled

29200011	Surcharge: TIG torch or spare-cable-assembly water-cooled length: 10m
29200012	Surcharge: TIG torch or spare-cable-assembly water-cooled length: 12m
29200016	Surcharge: TIG torch or spare-cable-assembly water-cooled length: 16m
29200020	Surcharge: TIG torch or spare-cable-assembly water-cooled length: 20m
29200024	Surcharge: TIG torch or spare-cable-assembly water-cooled length: 24m

Highly heat resistant and flexible cable-assemblies**HT 105 PVC-NIT fabric hose**

29000045	Surcharge: TIG gas- and water-cooled / 4m
29000085	Surcharge: TIG gas- and water-cooled / 8m

HT 110 rubber fabric hose

29000043	Surcharge: TIG gas- and water-cooled / 4m
29000083	Surcharge: TIG gas- and water-cooled / 8m

HT 130 TPE fabric hose

29000046	Surcharge: TIG gas- and water-cooled / 4m
29000086	Surcharge: TIG gas- and water-cooled / 8m

HT 180 Silicone-fabric hose (superflexible)

29000048	Surcharge: TIG gas- and water-cooled / 4m
29000088	Surcharge: TIG gas- and water-cooled / 8m

ST 80 PVC-NIT:

- Fabric hose 80° Shore
- Inner hose black, fine tension knit nylon-fabric
- best adhesion between inner- und outer hose, good pressure stability

HT 105 PVC-NIT:

- fabric hose inside 70°/outside 85° Shore
- Innerhose red, highly heat resistant
- Inner hose black, fine tension knit nylon-fabric
- best adhesion between inner- und outer hose, good pressure stability
- extremely flexible at 20°C and more due to its PVC-NIT inner- and outer hose

HT 110 Rubberfabric hose:

- Rubber hose black 75° Shore
- Very robust outer fabric, 100% covering outer weaving
- good adhesion of fabric due to fixation on the inner hose
- flexible at all temperatures, highly heat resistant

HT 130 TPE:

- Fabric hose
- Inner hose red fine tension knit nylon-fabric
- good pressure stability
- flexible at all temperatures, highly heat resistant

HT 180 Silicone:

- Fabric hose 65° Shore
- Very robust outer fabric, 100% covering outer weaving
- Extremely high heat resistant, up to 180°C
- flexible at all temperatures due high quality silicone-inner hose

D

Control line plugs and jacks

Art.-No.	
Control line plugs	
91904185	Plug 1-pole banana plug fits SAF
91903701	Plug 2-poles fits Cloos
91904151	Plug 2-poles Cannon fits ESAB
91904152	Plug 14-poles fits Miller
91904196	Plug 3-poles R3D3 "red dragon"
91904182	Headphone jack plug 3-poles 6,3mm fits Oerlikon
91904101	Plug 3-poles Tuchel with bayonet-catch
91904173	Plug 3-poles Alcatel fits Cloos-Herborn
91904174	Plug 3-poles Preh fits Ess / Jäckle / Gys
91904183	Plug 3-poles Amphenol fits TOP
91904186	Headphone jack plug 3-poles 3,5mm fits Lorch
91904131	Plug 4-poles Amphenol fits Kemppi / UTP
91904134	Plug 4-poles fits Selco
91904111	Plug 5-poles Tuchel with bayonet-catch
91904112	Plug 5-poles Tuchel screwable
91904172	Plug 5-poles fits Cebora
91904195	Plug 5-poles fits Selco / WECO / Cloos GL/GLW 202/222/30
91904169	Plug 6-poles fits CEA
91904121	Plug 6-poles Harting fits Migatronik
91904163	Plug 6-poles Schaltbau fits Elektra Beckum
91904113	Plug 7-poles Tuchel with bayonet-catch fits Castolin
91904161	Plug 7-poles fits Rehm / Migatronik / Hydrotech
91904165	Plug 7-poles fits Cloos with Poti
91904176	Plug 7-poles fits Cemont
91904178	Plug 7-poles fits Kemppi
91904194	Plug 7-poles fits STEL / Selco / WECO
91904189	Plug 8-poles Burdy fits EWM with Poti or up/down
91904164	Plug 9-poles flat connector fits Fronius
91904177	Plug 9-poles computer fits Lorch
91904175	Plug 10-poles fits Cebora
91904188	Plug 10-poles fits Kemppi with Poti
91904153	Plug 12-poles fits Flame
91904166	Plug 12-poles fits Rehm / HydroTech
91904167	Plug 12-poles Burdy fits EWM Tetrix
91904133	Plug 14-poles Amphenol fits Rówac
91904135	Plug 14-poles fits Miller
91904136	Plug 14-poles fits Telwin
Jacks	
91904149	Socket 2-poles Cannon
91904197	Socket 2-poles R2D2 "red dragon"
91904201	Socket 3-poles Tuchel with bayonet-catch
91904198	Socket 3-poles fits Alcatel
91904132	Socket 4-poles Amphenol fits Kemppi / UTP
91904211	Socket 5-poles Tuchel with bayonet-catch
91904162	Socket 7-poles fits Rehm
91904264	Socket 9-poles flat fits Fronius

Holch Schweißbrenner GmbH

Bühlstraße 14
57080 Siegen

Germany

Phone : + 49 (0) 271 387860 - 11 (sale)

Fax : + 49 (0) 271 387860 - 29

E - Mail : [info@holch - siegen.de](mailto:info@holch-siegen.de)

Web : [www. holch - siegen.de](http://www.holch-siegen.de)